



# RETROFIT TERMINALS

**Nailor**  
Industries Inc.

## Contents

	Page No.
<b>Product Overview</b>	<b>E3</b>
<b>Applications</b>	<b>E4</b>
<b>Model 36VRR • Round External Duct</b>	
Features, Options, Accessories	<b>E5</b>
Recommended Airflow Ranges	<b>E6</b>
Performance Data	<b>E7</b>
<b>Model 36VRS • Slide-in Rectangular or Square</b>	
Features, Options, Accessories	<b>E10</b>
Recommended Airflow Ranges	<b>E11</b>

## GENERAL PRODUCT OVERVIEW

### Retrofit Terminal Units

- Convert Constant Air Volume Systems to Variable Air Volume
  - Convert Constant Volume Dual Duct Systems to Variable Air Volume
  - Convert Multizone Systems to Variable Air Volume
  - Convert Mechanical Constant Volume Regulators to Low Pressure Pneumatic, Analog Electronic or Digital Controls.
- Nailor manufactures a range of standard and custom design retrofit terminal units for all applications.

### Round Duct External Retrofit Terminal Unit

Convert existing constant volume systems or old "system powered" mechanical regulator terminals to energy efficient variable volume operation.

- Available in 10 sizes to suit and install simply in round ductwork. 0 – 4050 cfm (0 – 1912 l/s).
- Various configurations custom fabricated to suit individual applications.
- Pressure dependent or independent airflow control.
- 'Diamond Flow' multi-point averaging flow sensor on pressure independent models.
- Pneumatic, electric, analog electronic or digital control.

**Model 36VRR**

**See page E5**

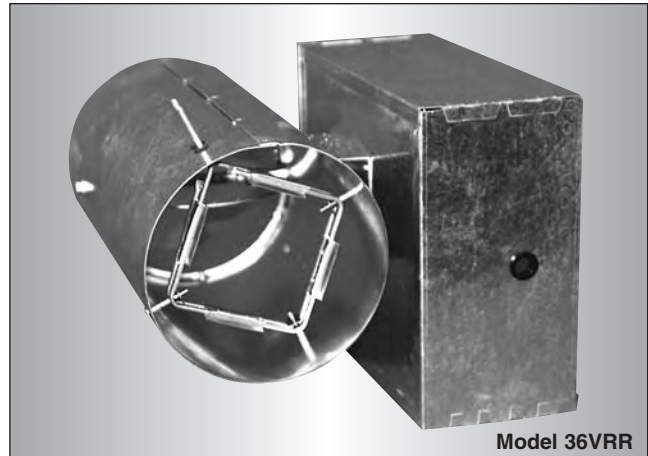

Model 36VRR

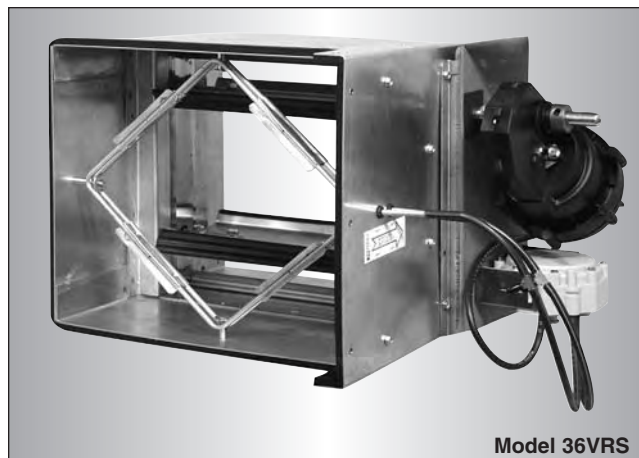

Model 36VRS

### Rectangular Slide-in Retrofit Terminal Unit

Convert existing constant volume systems to energy efficient variable volume operation.

- Available in 15 valve sizes to handle a large range of air volumes. 0 – 15000 cfm (0 – 7080 l/s).
- Custom fabricated to suit any duct size from 5" x 5" (127 x 127) up to 52" x 26" (1321 x 660).
- 'Diamond Flow' multi-point averaging sensor.
- Pressure independent airflow control.
- Pneumatic, analog electronic or digital control.

**Model 36VRS**

**See Page E10**

### Internal Retrofit Terminal Units

Designed to replace the mechanical regulators in old "system powered" terminal units in order to substantially lower the operational static pressure requirement. The air valves include a damper, flow sensor and actuator and make use of state-of-the-art controls in order to reduce operating cost.

- Custom built on a specific project basis.
- Variable or constant volume pressure independent airflow control.
- 'Diamond Flow' multi-point averaging flow sensor.
- Models available to retrofit most 'brand name' mechanical regulator design terminal units.
- Pneumatic, analog electronic or digital control.

**Model 36VR**

**Contact your Nailor Sales Rep.**

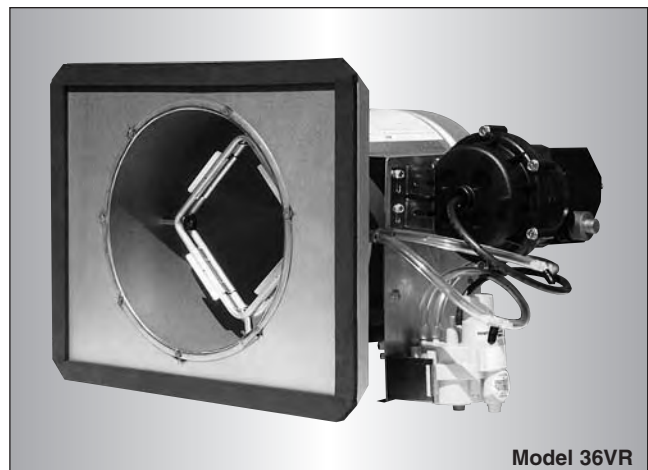

Model 36VR

## Some Typical Applications for the Model Series 36VR Retrofit VAV Terminals Dual Duct System

Hot and cold air from the central station is distributed through the existing supply ducts and terminals. The **Series 36VR Retrofit Terminals** will convert the constant volume system to variable air volume pressure independent operation.

Remove the mechanical constant volume regulator from the existing terminal, while a **Model 36VRS** is installed in the discharge box or duct. A direct acting thermostat controls both the **36VRS** unit and the modulating tandem damper in the existing box. On a rise in room temperature, the **36VRS** reduces the hot airflow. At the minimum setting, the damper in the existing terminal begins to modulate, and mixing occurs. A further temperature rise increases the cold airflow to the maximum.

The fan capacity may be reduced down since the total air volume is reduced.

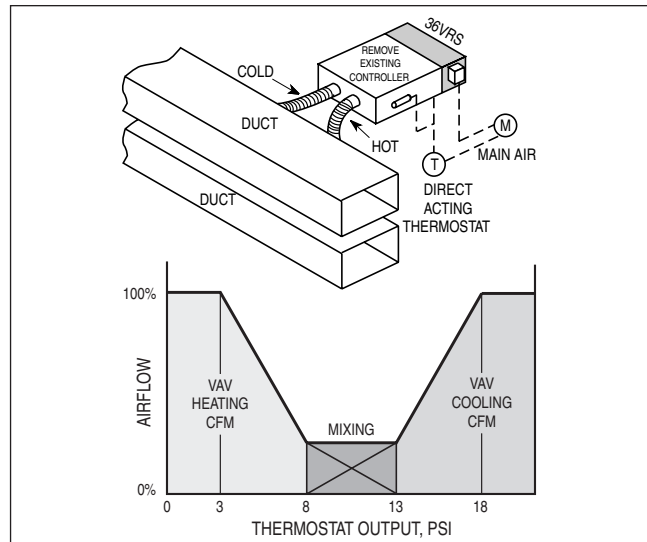

E

RETROFIT TERMINAL UNITS

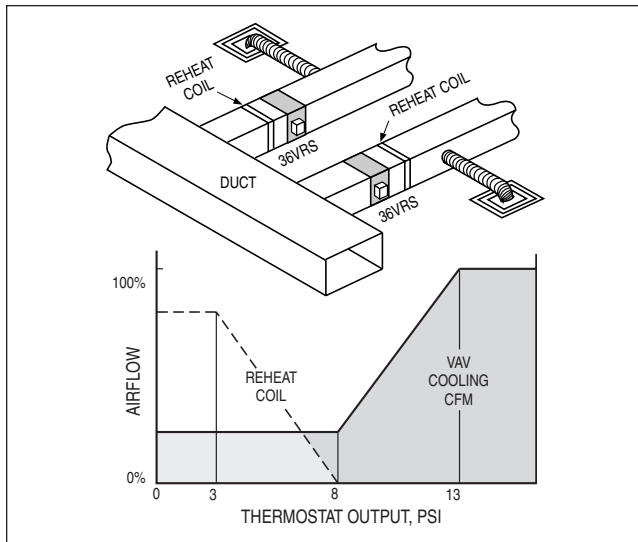

## Constant Volume Reheat System

Cold air from the central station is distributed through the existing main trunk and branch ducts. The **Model 36VRS Retrofit Terminals** will convert the constant volume system to pressure independent variable air volume operation.

Each **36VRS** terminal is signalled by a direct acting thermostat. The pressure independent minimum airflow is set at a thermostat output pressure of 8 psi or less, while the maximum is set at 13 psi or greater.

The existing reheat coil in each zone is actuated on a fall in room temperature, as the thermostat output decreases from 8 to 3 psi.

The fan capacity may be reduced since the total air volume is reduced.

## Multizone System

Hot or cold air from the central station multizone air handler is distributed through the existing zone system. The **Series 36VR Retrofit Terminals** will convert the multizone system to variable air volume operation.

The zone dampers in the central station air handler are made with two-position actuators; each zone is fully open, either heating or cooling. There is no mixing. (Controls may be selected for an outdoor thermostat, a manual selector or changeover signal.)

A dual function thermostat in each zone is direct acting for cooling, reverse acting for heating. In response to the room temperature, the thermostat resets the velocity controller for pressure independent control of the **Series 36VR**.

The fan capacity may be reduced since the total air volume is reduced.

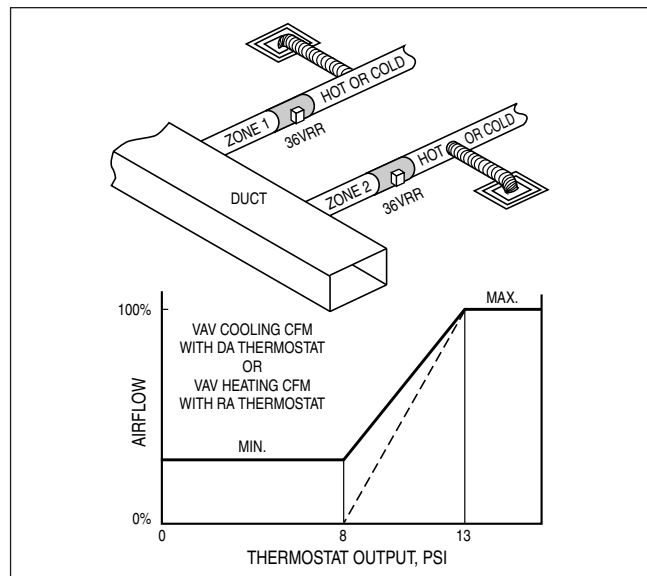

## ROUND EXTERNAL DUCT RETROFIT TERMINAL UNIT

### MODEL 36VRR

- VARIABLE AIR VOLUME  
CONVERSION

Model 36VRR is designed for round ductwork retrofit application. Terminals are available in 10 sizes and are nominally undersized to ensure a good fit.

Easy, low-cost installation into existing ductwork. The installer cuts out a section in the round duct and replaces the duct section with the conversion unit.

#### FEATURES:

- Casing 22 ga. (0.86), corrosion-resistant steel with stiffening beads. Size 14 and 16 are 20 ga. (0.91).
- Blade: Two layers of 22 ga. (0.86), corrosion-resistant steel laminated together (equivalent to 16 gauge) with a cross-linked polyurethane peripheral gasket for tight shut-off, 90° rotation, CCW to open. Damper leakage is less than 2% of nominal CFM @ 6" w.g. as tested in accordance with ANSI/ASHRAE Standard 130.
- Bearing: Self-lubricating oilite bronze.
- Drive Shaft/Axles: 1/2" (13) diameter plated steel, double-bolted to blades. Indicator mark on the end of the shaft to show damper position.
- Full electrical controls enclosure for factory mounted DDC and analog electronic controls.
- Multi-point averaging 'Diamond Flow' sensor: Aluminium.

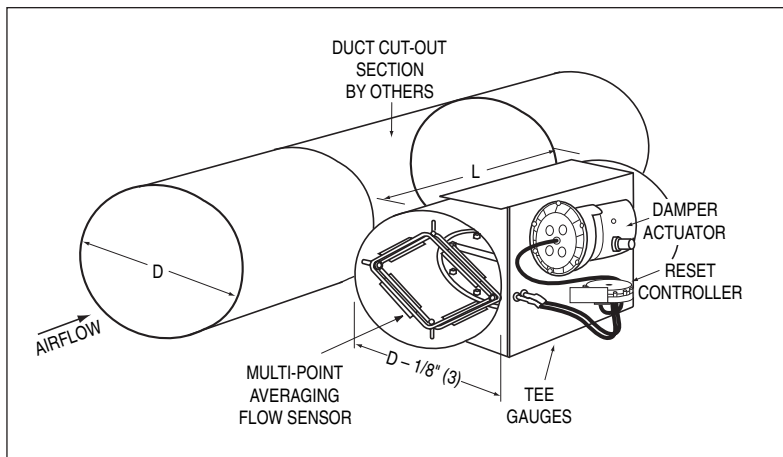

Gauge taps are provided for field balancing when controls are factory mounted.

- Right-hand control location is standard (as shown). Left-hand is optional.

#### Options:

- Available in Type 304 and 316 stainless steel construction for laboratory/fume hood exhaust applications.
- Controls enclosure for field mounted controls.
- 24 volt control transformer.
- Toggle disconnect switch.
- Pneumatic or Analog Electronic Pressure Independent controls by Nailor. Factory mounted and calibrated.
- Digital controls by BMS Contractor. Factory mounted by Nailor.

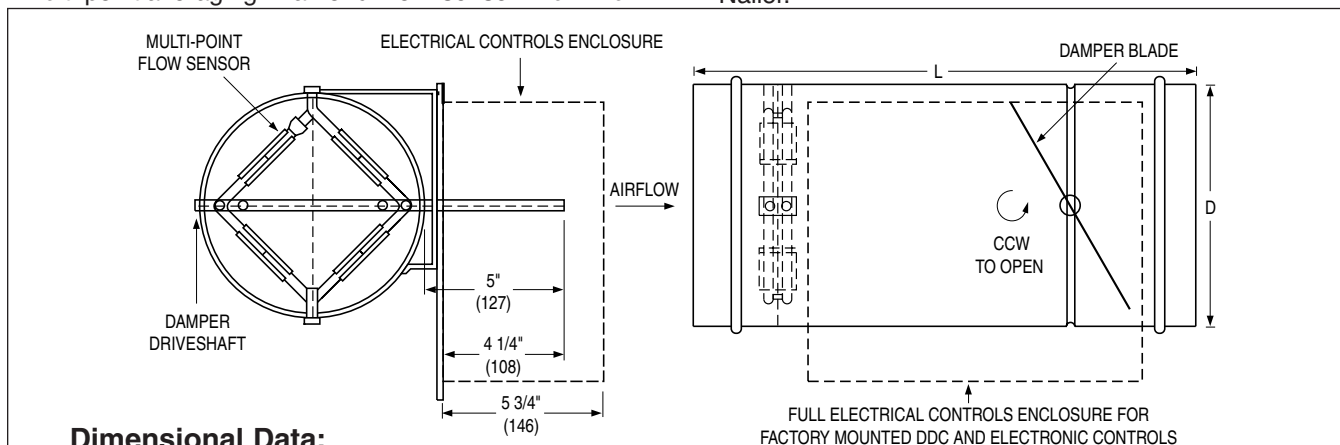

#### Dimensional Data:

Imperial Units (inches)			
Unit Size	cfm Range	D*	L
4	0 - 215	3 7/8	22
5	0 - 310	4 7/8	22
6	0 - 500	5 7/8	18
7	0 - 710	6 7/8	18
8	0 - 1000	7 7/8	18
9	0 - 1300	8 7/8	20
10	0 - 1435	9 7/8	20
12	0 - 2150	11 7/8	20
14	0 - 3060	13 7/8	22
16	0 - 4050	15 7/8	22

Metric Units (mm)			
Unit Size	l/s Range	D*	L
4	0 - 101	98	559
5	0 - 146	124	559
6	0 - 236	149	457
7	0 - 355	175	457
8	0 - 472	200	457
9	0 - 614	225	508
10	0 - 677	251	508
12	0 - 1015	302	508
14	0 - 1444	352	559
16	0 - 1912	403	559

\* Size 4 & 5 are supplied as a size 6 valve with reducers at both ends.

## Recommended Airflow Ranges For Model 36VRR Round Retrofit Terminal Units

The recommended airflow ranges below are for round duct terminal units with pressure independent controls and are based upon controller sensitivity limits as shown for each control type. For a given unit size, the minimum and the maximum flow settings for the hot and cold decks respectively must be within the range limits to ensure pressure independent operation, accuracy and repeatability. The high end of the tabulated Total Airflow Range represents the Diamond Flow Sensor's differential pressure reading at 1" w.g. (250 Pa). This is a common high limit for many VAV controllers, whether pneumatic or analog/DDC transducers. For these reasons, factory settings will not be made outside these ranges. A minimum setting of zero (shut-off) is also available.

Pneumatic control sequences utilize the 3000 Controller for its superior control characteristics. The constant reset span feature of this controller ensures that both the hot and cold decks track each other and respond over the same thermostat signal range regardless of the individual minimum and maximum settings which may be different. Control accuracy is therefore ensured.

ARI Standard 880 "Air Terminal Units" is the method of test for the certification program. The "standard rating condition" (certification rating point) airflow volumes for

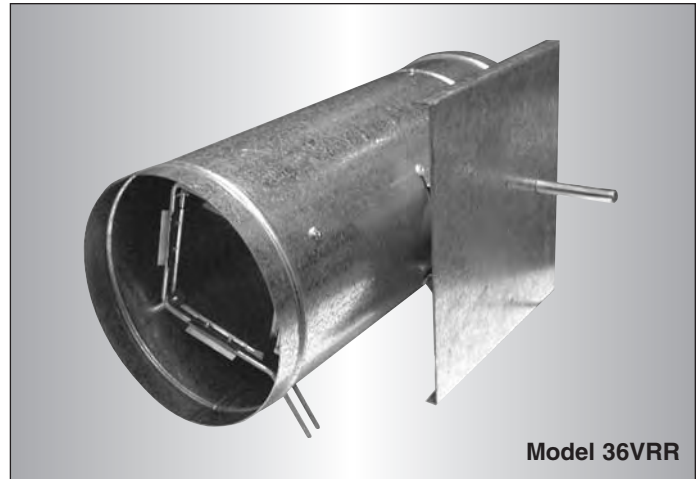

Model 36VRR

each terminal unit size are tabulated below. These air volumes equate to an approximate inlet velocity of 2000 fpm (10.2 m/s).

When digital or other controls are mounted by **Nailor**, but supplied by others, these values are guidelines only, based upon experience with the majority of controls currently available. Controls supplied by others for factory mounting are configured and calibrated in the field.

### Imperial Units, Cubic Feet per Minute

Unit Size	Total Airflow Range cfm	Airflow at 2000 fpm Inlet Velocity (nom.) cfm	Range of Minimum and Maximum Settings, cfm		
			Pneumatic 3000 Controller	Analog Electronic Controls	Digital Controls
			Min. – Max.	Min. – Max.	Min. – Max.
4	0 – 215	150	30 – 215	25 – 215	25 – 215
5	0 – 310	250	55 – 310	45 – 310	45 – 310
6	0 – 500	400	85 – 500	70 – 500	70 – 500
7	0 – 710	550	125 – 710	100 – 710	100 – 710
8	0 – 1000	700	180 – 1000	150 – 1000	150 – 1000
9	0 – 1300	900	210 – 1300	170 – 1300	170 – 1300
10	0 – 1435	1100	250 – 1435	205 – 1435	205 – 1435
12	0 – 2150	1600	395 – 2150	325 – 2150	325 – 2150
14	0 – 3060	2100	495 – 3060	400 – 3060	400 – 3060
16	0 – 4050	2800	760 – 4050	625 – 4050	625 – 4050

### Metric Units, Liters per Second

Unit Size	Total Airflow Range l/s	Airflow at 10.2 m/s Inlet Velocity (nom.) l/s	Range of Minimum and Maximum Settings, l/s		
			Pneumatic 3000 Controller	Analog Electronic Controls	Digital Controls
			Min. – Max.	Min. – Max.	Min. – Max.
4	0 – 101	71	14 – 101	12 – 101	12 – 101
5	0 – 146	118	26 – 146	21 – 146	21 – 146
6	0 – 236	189	40 – 236	33 – 236	33 – 236
7	0 – 355	260	59 – 355	47 – 355	47 – 355
8	0 – 472	330	85 – 472	71 – 472	71 – 472
9	0 – 614	425	99 – 614	80 – 614	80 – 614
10	0 – 677	519	118 – 677	97 – 677	97 – 677
12	0 – 1015	755	186 – 1015	153 – 1015	153 – 1015
14	0 – 1444	991	234 – 1444	189 – 1444	189 – 1444
16	0 – 1912	1322	359 – 1912	295 – 1912	295 – 1912

## Performance Data • NC Level Application Guide Model 36VRR

Inlet Size	Airflow		Min. inlet ΔPs		NC Levels @ Inlet Pressure (ΔPs) shown							
					DISCHARGE				RADIATED			
					0.5" w.g.	1.0" w.g.	1.5" w.g.	3.0" w.g.	0.5" w.g.	1.0" w.g.	1.5" w.g.	3.0" w.g.
cfm	l/s	" w.g.	Pa	125 Pa	250 Pa	375 Pa	750 Pa	125 Pa	250 Pa	375 Pa	750 Pa	
4	225	106	0.25	62	-	-	20	25	-	21	24	30
	200	94	0.20	50	-	-	-	24	-	-	-	22
	150	71	0.10	25	-	-	-	-	-	-	-	-
	100	47	0.05	12	-	-	-	-	-	-	-	-
5	350	165	0.32	80	-	20	25	29	-	26	26	33
	300	142	0.23	57	-	-	22	26	-	21	23	30
	200	94	0.11	27	-	-	-	21	-	-	-	20
	100	47	0.03	7	-	-	-	-	-	-	-	-
6	450	212	0.22	55	-	-	20	26	20	24	27	32
	400	189	0.18	45	-	-	25	24	-	22	24	30
	300	142	0.10	25	-	-	-	-	-	-	-	28
	200	94	0.04	10	-	-	-	-	-	-	-	-
7	650	307	0.21	52	-	20	24	30	-	26	28	33
	550	260	0.14	35	-	-	20	27	-	22	24	27
	450	212	0.10	25	-	-	-	22	-	-	-	25
	350	165	0.06	15	-	-	-	-	-	-	-	-
8	800	378	0.17	42	-	22	25	26	-	26	26	33
	700	330	0.13	32	-	20	22	25	-	24	24	27
	600	283	0.10	25	-	-	20	23	-	-	21	26
	400	189	0.04	10	-	-	-	-	-	-	-	-
9	1050	496	0.17	42	21	26	26	30	-	25	29	35
	850	401	0.11	27	-	23	23	26	-	21	25	32
	650	307	0.07	17	-	-	-	25	-	-	-	26
	450	212	0.03	7	-	-	-	21	-	-	-	21
10	1350	637	0.16	40	-	21	26	31	21	27	31	36
	1150	543	0.12	30	-	-	25	27	-	24	27	33
	950	448	0.09	22	-	-	25	26	-	20	23	30
	750	354	0.05	12	-	-	-	25	-	-	-	25
12	2100	991	0.19	47	-	25	29	34	24	33	36	39
	1700	802	0.12	30	-	22	26	31	23	28	31	35
	1300	614	0.07	17	-	-	24	27	-	22	25	30
	900	425	0.03	7	-	-	21	25	-	-	-	21
14	3200	1510	0.25	62	28	32	34	38	30	35	37	42
	2700	1274	0.19	47	27	30	32	36	26	31	33	37
	2200	1038	0.12	30	23	27	30	32	21	26	29	34
	1700	802	0.06	15	-	21	27	27	-	21	23	27
16	4000	1888	0.21	52	25	29	35	39	31	36	39	45
	3500	1652	0.15	37	24	26	31	36	26	33	35	40
	3000	1416	0.11	27	22	23	30	34	23	30	32	37
	2000	944	0.04	10	-	23	28	31	-	-	28	27

### Performance Notes:

1. NC levels are calculated from the published raw data and based on procedures outlined in Appendix E, ARI 885-98.
2. Discharge sound attenuation deductions are based on environmental effect, duct lining, branch power division, insulated flex duct, end reflection and space effect and are as follows:

Discharge attenuation	Octave Band						
	2	3	4	5	6	7	
< 300 cfm	24	28	39	53	58	40	
300 – 700 cfm	27	29	40	51	53	39	
> 700 cfm	29	30	41	51	52	39	

3. Radiated sound attenuation deductions are based on a mineral tile ceiling and environmental effect and are as follows:

Radiated attenuation	Octave Band						
	2	3	4	5	6	7	
Total dB reduction	18	19	20	26	31	36	

4. Min. inlet ΔPs is the minimum static pressure required to achieve rated airflow (damper full open).
5. Dash (–) in space denotes an NC level of less than 20.
6. For a complete explanation and details on NC calculations, refer to page B9 and the engineering section of this catalog.

## Performance Data • Discharge Sound Power Levels

### Model 36VRR

**RETROFIT TERMINAL UNITS**

Unit Size	Airflow		Min. inlet ΔPs "w.g. Pa	Sound Power Octave Bands Center @ Inlet Pressure ΔPs shown																														
	cfm	l/s		0.5" w.g. (125 Pa) ΔPs							1.0" w.g. (250 Pa) ΔPs							1.5" w.g. (375 Pa) ΔPs							3.0" w.g. (750 Pa) ΔPs									
				2	3	4	5	6	7	2	3	4	5	6	7	2	3	4	5	6	7	2	3	4	5	6	7	2	3	4	5	6	7	
4	225	106	0.25	62	58	51	51	46	45	62	57	60	56	52	51	65	58	60	58	54	56	69	62	66	62	59	62	69	62	66	62	59	62	
	200	94	0.20	50	56	50	50	49	45	44	61	55	55	54	51	50	64	57	58	56	53	54	68	61	62	61	58	60	68	61	62	61	58	60
	150	71	0.10	25	52	46	46	45	42	43	57	50	51	50	47	45	60	53	54	52	50	50	64	57	58	55	54	55	64	57	58	55	54	55
	100	47	0.05	12	47	40	42	35	37	38	52	44	46	44	41	40	55	47	49	47	44	46	59	51	54	50	44	48	59	51	54	50	44	48
5	350	165	0.32	80	58	52	51	52	49	50	63	57	56	55	54	56	64	61	60	58	57	60	70	66	65	63	62	66	70	66	65	63	62	66
	300	142	0.23	57	56	55	50	50	48	49	61	55	54	53	52	54	64	54	57	56	55	58	68	64	63	61	60	62	68	64	63	61	60	62
	200	94	0.11	27	50	45	45	45	42	44	56	50	50	49	47	49	58	53	53	51	50	53	64	59	58	56	55	58	64	59	58	56	55	58
	100	47	0.03	7	44	36	37	36	33	35	48	41	42	40	39	43	51	44	45	43	42	46	56	50	51	47	46	48	56	50	51	47	46	48
6	450	212	0.22	55	60	54	53	52	52	46	64	59	58	58	57	51	67	62	61	60	59	54	71	67	65	63	63	56	71	67	65	63	63	56
	400	189	0.18	45	58	52	51	52	51	44	63	57	56	57	56	49	65	66	59	58	57	52	69	65	63	62	61	55	69	65	63	62	61	55
	300	142	0.10	25	55	48	48	49	46	42	59	53	52	52	51	45	62	56	55	54	53	48	66	60	60	58	57	52	66	60	60	58	57	52
	200	94	0.04	10	50	42	43	44	42	40	54	47	47	42	46	41	57	50	50	49	48	44	61	55	55	52	53	49	61	55	55	52	53	49
7	650	307	0.21	52	61	57	57	58	56	49	66	62	61	61	59	53	69	65	64	63	62	58	74	70	68	66	66	62	74	70	68	66	66	62
	550	260	0.14	35	59	54	54	56	53	47	64	60	60	58	57	51	67	62	63	62	60	56	71	68	66	63	63	60	71	68	66	63	63	60
	450	212	0.10	25	57	52	52	53	51	45	61	57	56	51	54	48	64	60	59	58	57	54	69	64	64	61	60	56	69	64	64	61	60	56
	350	165	0.06	15	54	58	49	49	47	40	59	53	53	52	51	45	61	56	56	55	53	50	66	61	60	57	57	54	66	61	60	57	57	54
8	800	378	0.17	42	61	55	55	56	55	53	65	61	60	60	59	58	68	63	62	62	61	60	73	68	66	65	65	62	73	68	66	65	65	62
	700	330	0.13	32	59	54	54	55	54	51	64	59	58	58	58	56	66	62	61	61	60	58	71	66	65	64	64	60	71	66	65	64	64	60
	600	283	0.10	25	58	52	53	52	52	49	62	57	56	56	56	54	65	59	59	58	58	56	69	64	64	63	61	58	69	64	64	63	61	58
	400	189	0.04	10	55	47	47	47	46	42	58	53	52	52	52	47	61	55	55	53	52	50	65	60	59	57	56	55	65	60	59	57	56	55
9	1050	496	0.17	42	63	58	59	58	57	52	67	63	63	62	61	57	70	65	66	65	63	62	75	71	70	68	65	65	75	71	70	68	65	65
	850	401	0.11	27	60	55	57	56	53	50	62	60	61	60	58	54	67	63	63	62	61	59	73	67	67	66	65	62	73	67	67	66	65	62
	650	307	0.07	17	57	52	53	53	50	46	62	57	57	56	55	51	65	60	60	59	58	55	70	65	64	62	62	60	70	65	64	62	62	60
	450	212	0.03	7	53	48	49	48	46	41	57	52	53	52	51	44	61	55	56	54	53	50	65	60	60	59	58	57	65	60	60	59	58	57
10	1350	637	0.16	40	64	58	59	57	57	53	69	63	63	61	61	57	72	67	66	64	64	62	77	72	71	69	68	65	77	72	71	69	68	65
	1150	543	0.12	30	62	56	57	56	55	51	67	61	61	60	59	55	70	65	65	62	62	61	73	69	68	66	66	63	73	69	68	66	66	63
	950	448	0.09	22	60	53	55	53	52	49	65	59	59	58	57	54	68	62	63	60	59	60	73	67	66	64	64	62	73	67	66	64	64	62
	750	354	0.05	12	57	50	52	50	50	47	62	55	56	54	54	51	64	59	59	51	56	54	70	64	63	62	60	61	70	64	63	62	60	61
12	2100	991	0.19	47	66	62	62	61	60	55	72	67	66	66	64	59	75	70	69	67	67	64	80	73	73	72	72	69	80	73	73	72	72	69
	1700	802	0.12	30	64	59	59	58	57	53	69	64	64	62	61	58	72	67	66	64	64	62	77	72	71	69	68	67	77	72	71	69	68	67
	1300	614	0.07	17	60	55	56	54	53	50	66	61	60	58	58	55	69	64	63	61	60	60	74	68	67	65	64	64	74	68	67	65	64	64
	900	425	0.03	7	56	51	51	50	49	47	61	56	56	53	52	52	64	59	58	56	55	57	70	64	62	60	59	60	70	64	62	60	59	60
14	3200	1510	0.25	62	69	66	65	64	63	65	75	71	70	67	66	69	78	74	72	70	69	71	83	79	76	74	73	73	83	79	76	74	73	73
	2700	1274	0.19	47	67	63	63	61	61	63	72	68	67	65	65	67	75	71	70	68	67	69	80	76	74	71	71	72	80	76	74	71	71	72
	2200	1038	0.12	30	64	60	60	58	58	59	69	65	65	63	63	64	72	68	67	65	64	67	77	73	71	70	68	69	77	73	71	70	68	69
	1700	802	0.06	15	61	56	57	55	55	53	66	61	61	59	59	57	69	64	64	61	61	59	74	69	68	66	64	62	74	69	68	66	64	62
16	4000	1888	0.21	52	69	64	65	63	62	61	74	70	70	67	67	66	77	73	72	70	70	72	83	78	77	74	73	75	83	78	77	74	73	75
	3500	1652	0.15	37	68	63	63	62	61	60	73	68	68	66	65	62	76	72	71	68	67	68	81	77	75	72	71	72	81	77	75	72	71	72
	3000	1416	0.11	27	66	60	62	60	59	58	71	65	66	63	63	59	73	69	69	66	66	67	78	74	73	70	68	70	78	74	73	70	68	70
	2000	944	0.04	10	61	54	56	54	53	53	65	59	60	58	58	59	68	63	63	61	60	65	73	69	67	65	65	68	73	69	67	65	65	68

#### Performance Notes:

- Discharge sound power is the noise emitted from the unit discharge into the downstream duct.
- Sound power levels are in decibels, dB re 10<sup>-12</sup> watts.
- All sound data listed by octave bands is raw data without any corrections for room absorption or duct attenuation.
- Min. inlet ΔPs is the minimum operating pressure requirement (damper full open).
- Data derived from tests conducted in accordance with ANSI/ASHRAE Std. 130-1996 and ARI Standard 880-98.



## Performance Data • Radiated Sound Power Levels

### Model 36VRR

Unit Size	Airflow		Min. inlet ΔPs		Sound Power Octave Bands Center @ Inlet Pressure ΔPs shown																											
					0.5" w.g. (125 Pa) ΔPs							1.0" w.g. (250 Pa) ΔPs							1.5" w.g. (375 Pa) ΔPs							3.0" w.g. (750 Pa) ΔPs						
	cfm	l/s	"w.g.	Pa	2	3	4	5	6	7	2	3	4	5	6	7	2	3	4	5	6	7	2	3	4	5	6	7				
4	225	106	0.25	62	50	42	42	44	47	40	53	44	45	49	51	44	55	48	48	50	54	49	60	54	55	55	58	52				
	200	94	0.20	50	49	37	38	40	44	38	48	40	42	45	47	40	50	43	45	46	49	41	53	45	47	49	52	45				
	150	71	0.10	25	24	26	27	33	35	27	40	31	35	38	39	33	46	35	37	40	45	38	49	43	43	45	48	40				
	100	47	0.05	12	-	-	-	24	28	-	-	-	26	29	34	26	-	21	26	30	37	31	42	33	34	36	40	34				
5	350	165	0.32	80	54	45	45	46	47	41	55	51	52	52	54	46	60	52	52	53	55	50	65	57	58	58	60	55				
	300	142	0.23	57	49	41	41	42	46	37	50	47	47	48	50	43	58	49	49	51	52	46	60	53	55	57	59	52				
	200	94	0.11	27	43	26	35	38	40	27	42	38	39	41	44	33	48	40	41	43	45	36	53	45	46	46	48	42				
	100	47	0.03	7	-	-	21	23	25	-	-	-	21	29	32	-	-	-	22	33	36	21	41	31	35	36	40	26				
6	450	212	0.22	55	53	45	44	48	49	42	57	50	49	52	53	48	59	51	51	55	55	51	63	57	57	59	59	56				
	400	189	0.18	45	51	42	42	46	41	39	55	47	47	50	51	45	57	50	50	52	53	48	61	52	54	57	58	53				
	300	142	0.10	25	46	37	37	40	41	32	50	42	42	44	46	37	52	44	44	47	48	41	56	49	48	51	52	46				
	200	94	0.04	10	30	25	28	32	34	22	43	23	34	37	39	27	45	36	37	39	41	30	49	41	41	44	45	36				
7	650	307	0.21	52	53	44	44	42	48	45	59	52	52	53	54	51	61	52	53	52	54	54	64	58	58	57	59	64				
	550	260	0.14	35	49	42	42	43	46	41	56	49	48	49	52	47	58	50	50	51	52	50	59	54	53	54	56	60				
	450	212	0.10	25	45	38	37	39	43	36	51	43	43	44	46	42	52	44	45	45	47	45	55	50	51	52	54	53				
	350	165	0.06	15	40	34	34	32	36	30	44	35	36	38	41	35	50	41	42	43	44	39	52	44	45	45	47	49				
8	800	378	0.17	42	54	45	45	44	47	44	58	51	52	50	52	50	62	53	52	53	54	54	65	58	58	57	60	59				
	700	330	0.13	32	52	43	43	41	45	41	57	50	50	51	51	46	59	50	50	49	53	51	60	54	53	54	57	56				
	600	283	0.10	25	48	39	38	37	43	37	53	44	44	46	49	42	55	46	47	48	49	47	58	51	52	52	55	52				
	400	189	0.40	10	44	32	30	29	35	27	43	34	35	35	40	32	49	40	42	43	44	37	51	43	44	43	46	42				
9	1050	496	0.17	42	56	47	45	45	48	47	60	52	51	51	52	53	63	55	54	54	55	56	67	61	60	59	62	62				
	850	401	0.11	27	53	43	43	43	44	42	56	47	47	46	49	47	59	51	50	48	53	51	63	56	57	56	58	56				
	650	307	0.07	17	46	36	35	34	42	35	51	42	41	41	43	41	54	45	44	45	47	44	59	53	52	52	54	50				
	450	212	0.03	7	42	29	27	26	30	26	47	34	33	32	37	32	49	35	36	35	45	35	51	46	47	45	49	41				
10	1350	637	0.16	40	58	49	47	47	49	48	62	54	53	52	53	53	64	57	56	56	57	60	69	63	61	61	63	62				
	1150	543	0.12	30	56	46	45	44	46	45	59	51	50	49	52	50	61	54	53	53	55	53	65	59	58	58	60	58				
	950	448	0.09	22	52	42	41	41	43	41	56	48	46	46	48	45	58	51	49	49	51	48	62	55	55	54	56	55				
	750	354	0.05	12	48	38	37	36	38	35	53	43	42	41	44	40	54	47	45	44	47	44	58	52	50	49	52	49				
12	2100	991	0.19	47	63	55	54	53	53	52	66	59	58	57	58	58	68	62	61	59	62	61	72	66	65	64	65	66				
	1700	802	0.12	30	57	51	49	48	49	48	61	55	54	51	54	53	64	57	56	55	57	57	68	61	60	59	61	61				
	1300	614	0.07	17	52	45	44	43	44	41	56	48	48	47	48	47	58	51	51	50	52	50	62	54	55	51	56	55				
	900	425	0.03	7	45	37	36	36	37	32	48	40	40	39	42	38	51	42	42	42	44	41	55	46	47	46	49	47				
14	3200	1510	0.25	62	66	57	55	53	55	59	70	62	58	57	59	63	72	67	63	61	62	65	75	68	67	65	66	70				
	2700	1274	0.19	47	63	54	52	50	52	51	66	58	56	54	56	57	68	61	58	56	58	61	72	65	63	61	63	67				
	2200	1038	0.12	30	58	50	47	46	47	46	62	53	52	50	52	52	64	56	54	53	55	56	67	60	59	58	60	62				
	1700	802	0.06	15	53	44	42	41	43	41	56	48	47	45	47	46	58	50	49	48	46	50	62	55	53	52	55	55				
16	4000	1888	0.21	52	67	58	56	53	56	57	71	62	60	59	61	62	73	64	64	61	63	66	76	70	69	66	68	71				
	3500	1652	0.15	37	65	55	52	51	54	54	68	60	58	56	58	59	70	62	60	58	59	61	73	67	66	64	65	67				
	3000	1416	0.11	27	61	51	49	47	50	50	65	56	55	53	54	55	67	58	57	55	58	58	70	63	62	60	62	63				
	2000	944	0.04	10	52	42	40	39	42	40	56	47	45	44	47	45	58	49	49	46	49	48	62	53	53	52	54	53				

#### Performance Notes:

1. Radiated sound power is the breakout noise transmitted through the unit casing walls.
2. Sound power levels are in decibels, dB re 10<sup>-12</sup> watts.
3. All sound data listed by octave bands is raw data without any corrections for room absorption or duct attenuation.

4. Min. inlet ΔPs is the minimum operating pressure requirement (damper full open).
5. Data derived from tests conducted in accordance with ANSI/ASHRAE Std. 130-1996 and ARI Standard 880-98.

## SLIDE-IN RETROFIT TERMINAL UNIT MODEL 36VRS

- SQUARE OR RECTANGULAR
- VARIABLE AIR VOLUME CONVERSION

A slide-in type Retrofit Air Terminal Unit for square or rectangular ductwork. Converts constant volume systems to variable air volume. Available in 15 individual valve sizes up to 15,000 cfm. Nominal valve size is the same as smallest available duct size in table.

Each unit (valve) size is available to suit various duct sizes as shown in the table. Top, bottom and/or side blank-off plates are used to bring valve up to the required nominal ductwork dimension. Airflow ranges are based on valve size and acoustical considerations for duct velocity. Model 36VRS units are available to suit duct sizes within the tabulated range in 1" (25) increments.

Simple, low cost installation into existing ductwork. The installer cuts a rectangular hole in the side of the duct, cuts away the insulation (where present), slides the unit into the duct and screws the mounting plate to the side of the duct.

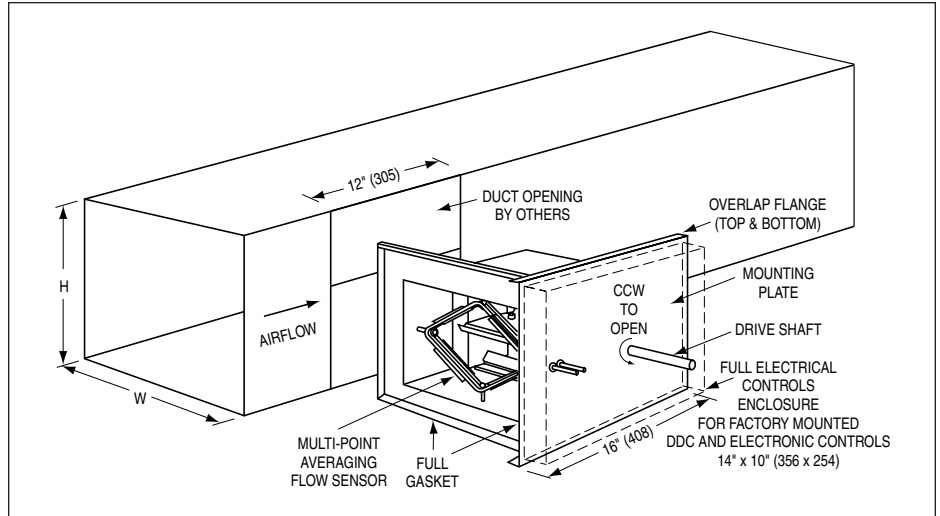

### FEATURES:

- Damper: 16 ga. (1.6) galvanized steel blade and frame construction with extruded PVC blade seals and metallic side jamb seals. Leakage is less than 2% of nominal CFM @ 3.0" w.g. as tested in accordance with ASHRAE Standard 130.
- Bearings: Celcon®.
- Drive Shaft: 1/2" (13) dia. plated steel, double-bolted to blade. Indicator mark on the end of the shaft to show damper position. 90° rotation. CW to close.
- Full electrical controls enclosure for factory mounted DDC and analog electronic controls.
- Multi-point averaging 'Diamond Flow' sensor: Aluminum. Gauge taps are provided for field balancing

when controls are factory mounted.

- Gasket under the mounting plate and around periphery of terminal insert seal the unit to the sides of the duct.

### Options:

- Controls enclosure for field mounted controls.
- 24 volt control transformer.
- Toggle disconnect switch.
- Pneumatic or Analog Electronic Pressure Independent controls by Nailor. Factory mounted and calibrated.
- Digital controls by BMS Contractor. Factory mounted by Nailor.

### Dimensional Data:

Unit (valve) Size	Available Duct Size Width x Height	
	inches	mm
7	5 x 5 to 12 x 8	127 x 127 to 305 x 203
8	6 x 6 to 12 x 10	152 x 152 to 305 x 254
9	8 x 6 to 16 x 10	203 x 152 to 406 x 254
10	10 x 8 to 18 x 12	254 x 203 to 457 x 305
11	14 x 8 to 22 x 12	356 x 203 to 559 x 305
11A	18 x 6 to 26 x 10	457 x 152 to 660 x 254
12	12 x 10 to 22 x 14	305 x 254 to 559 x 356
13	18 x 10 to 28 x 14	457 x 254 to 711 x 356
14	18 x 12 to 28 x 16	457 x 305 to 711 x 406
15	20 x 14 to 30 x 18	508 x 356 to 762 x 457
15A	30 x 12 to 36 x 16	762 x 305 to 914 x 406
16	22 x 16 to 36 x 20	559 x 406 to 914 x 508
17	24 x 18 to 36 x 26	610 x 457 to 914 x 660
18	30 x 20 to 46 x 26	762 x 508 to 1168 x 660
19	40 x 20 to 52 x 26	1016 x 508 to 1321 x 660

## Recommended Airflow Ranges For Model 36VRS Slide-in Retrofit Terminal Units

The recommended airflow ranges below are for terminal units with pressure independent controls and are based upon controller sensitivity limits as shown for each control type and acoustical consideration for duct velocity. For a given unit size, the minimum, auxiliary minimum (where applicable) and the maximum flow settings must be within the range limits to ensure pressure independent operation, accuracy and repeatability. For these reasons, factory settings will not be made outside these ranges. A minimum setting of zero (shut-off) is also available. Where an auxiliary setting is specified, the value must be greater than the minimum setting.

When digital or other controls are mounted by Nailor, but supplied by others, these values are guidelines only, based upon experience with the majority of controls currently available. Controls supplied by others for factory mounting are configured and calibrated in the field.

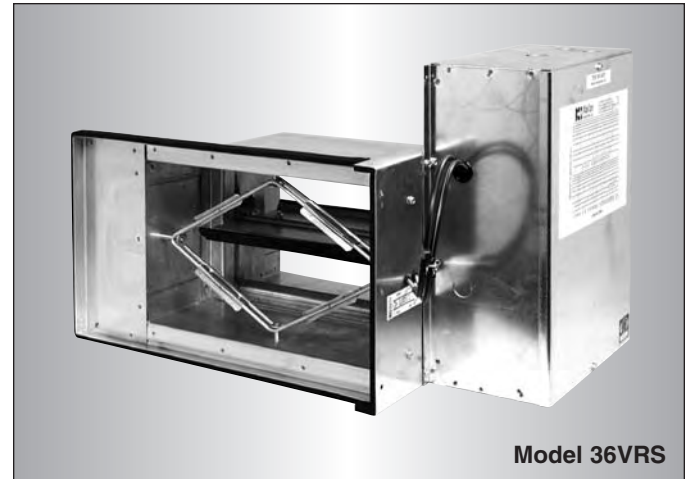

Model 36VRS

E

RETROFIT TERMINAL UNITS

Model 36VRS Square or Rectangular							
Unit Size	Nom. Valve Size	Min. – Max. Airflow Range				Available Duct Size	
		Pneumatic		Digital/Analog		Width x Height	
		cfm	l/s	cfm	l/s	inches	mm
7	5 x 5	70 - 200	33 - 94	60 - 200	28 - 94	5 x 5 to 12 x 8	127 x 127 to 305 x 203
8	6 x 6	110 - 300	52 - 142	85 - 300	40 - 142	6 x 6 to 14 x 10	152 x 152 to 356 x 254
9	8 x 6	140 - 400	66 - 189	110 - 400	52 - 189	8 x 6 to 16 x 10	203 x 152 to 406 x 254
10	10 x 8	240 - 700	113 - 330	180 - 700	85 - 330	10 x 8 to 18 x 12	254 x 203 to 457 x 305
11	14 x 8	320 - 1000	151 - 472	260 - 1000	123 - 472	14 x 8 to 24 x 12	356 x 203 to 610 x 305
11A	18 x 6	310 - 1000	146 - 472	250 - 1000	118 - 472	18 x 6 to 26 x 10	457 x 152 to 660 x 254
12	12 x 10	350 - 1100	165 - 519	280 - 1100	132 - 519	12 x 10 to 22 x 14	305 x 254 to 559 x 356
13	18 x 10	500 - 1900	236 - 897	435 - 1900	205 - 897	18 x 10 to 30 x 14	457 x 254 to 762 x 356
14	18 x 12	650 - 2400	307 - 1133	540 - 2400	255 - 1133	18 x 12 to 28 x 16	457 x 305 to 711 x 406
15	20 x 14	850 - 3800	401 - 1794	700 - 3800	330 - 1794	20 x 14 to 30 x 18	508 x 356 to 762 x 457
15A	30 x 12	1020 - 5400	481 - 2549	870 - 5400	411 - 2549	30 x 12 to 36 x 16	762 x 305 to 914 x 406
16	22 x 16	1000 - 5400	472 - 2549	850 - 5400	401 - 2549	22 x 16 to 36 x 20	559 x 406 to 914 x 508
17	24 x 18	1250 - 6700	590 - 3162	1100 - 6700	519 - 3162	24 x 18 to 36 x 26	610 x 457 to 914 x 660
18	30 x 20	1750 - 10000	826 - 4720	1500 - 10000	708 - 4720	30 x 20 to 46 x 26	762 x 508 to 1168 x 660
19	40 x 20	2300 - 15000	1085 - 7080	1900 - 15000	897 - 7080	40 x 20 to 52 x 26	1016 x 508 to 1321 x 660

**Notes:**



**RETROFIT TERMINAL UNITS**