



UNDERFLOOR FAN POWERED TERMINAL UNITS

 **Nailor**
Industries Inc.

Contents

	Page No.
Underfloor Fan Powered Terminal Units	
Model 38S, 38SE, 38SW	
Features, Options, Accessories	D3
Dimensional Data	
Model 38S	D4
Model 38SW with Hot water Coils	D5
Model 38SE with Electric Heat	D5
Performance Data	
Fan Curves	D6
Sound Power Levels	D7
Hot Water Coils	D9
Electric Heating Coils	D12
Controls	D14
Optional Terminal Unit Liners for 'IAQ' Sensitive Applications	D16
Suggested Specifications	D17

UNDERFLOOR FAN POWERED TERMINAL UNITS

SERIES FLOW CONSTANT VOLUME

38S SERIES

Models:

38S	No Heat
38SE	Electric Heat
38SW	Hot Water Heat

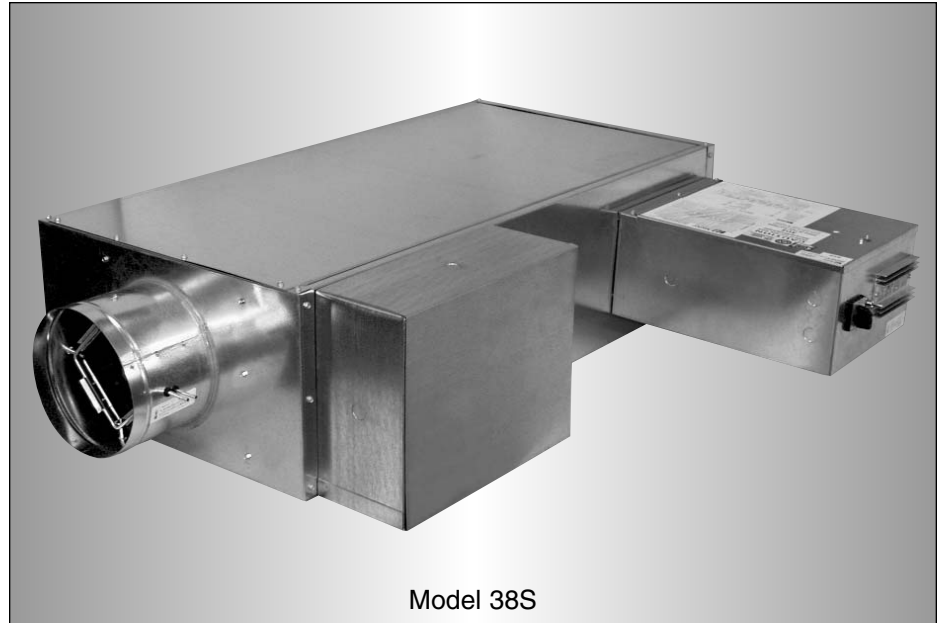

Model 38S

The **Nailor Model Series 38S Underfloor Fan Powered Terminal Units** are specially engineered to meet the requirements of the most demanding underfloor applications where premium quality design and performance characteristics are desired. Features include an inclined opposed damper and our multi-point averaging 'Diamond Flow' sensor to provide precise airflow control and excellent sound performance. Compact, low profile unit casings, designed to accommodate the floor pedestal layout, feature convenient access to all components.

Designed to optimize energy efficiency the standard units feature ultra-high efficiency EPIC™/ECM motor technology. Additional options include electric or hot water supplementary heat, and various 'IAQ' linings including a solid metal liner.

STANDARD FEATURES:

- 20 ga. (1.0) galvanized steel construction.
- 16 ga. (1.6) galvanized steel inclined opposed blade primary air damper. 45° rotation, CW to close. 1/2" (13) dia. plated steel drive shaft. An indicator mark on the end of the shaft shows damper-position. Leakage is less than 2% of nominal flow at 3" w.g. (750 Pa).
- Multi-point averaging 'Diamond Flow' sensor.
- Perforated baffle on primary air discharge optimizes mixing with induced air for rapid and effective temperature equalization. The baffle also converts low frequency primary air valve generated sound into more readily attenuated higher frequencies.
- Pressure independent primary airflow control.
- Full size top access panel.
- 1/2" (13) dual density insulation. Exposed edges coated to prevent air erosion. Meets requirements of NFPA 90A and UL 181.

- Single point electrical connection.
- Discharge opening designed for flanged duct connection.
- Top access hinged door line voltage / fan controls enclosure.
- Full primary air valve low voltage enclosure for factory mounted DDC and analog electronic controls.
- Ultra-energy efficient ECM fan motor with overload protection. Solid state Nailor EPIC™ fan volume controller.
- Available with electric or hot water supplementary heat.
- All controls are mounted on exterior of terminal providing ready access for field adjustment.
- Each terminal factory tested prior to shipment.

CONTROLS:

- Analog electronic controls. Factory supplied, mounted and calibrated.
- Digital controls. Factory mounting and wiring of DDC controls supplied by BMS Controls Contractor.

OPTIONS AND ACCESSORIES:

- Primary air valve controls enclosure for field mounted controls.
- Filter frame and 1" (25)/2" (51) disposable filter.
- Rubber support feet.
- Toggle disconnect switch.
- Steri-liner.
- Fiber-free liner.
- Solid metal liner.
- Perforated metal liner.
- Fan unit fusing.
- Left-hand controls location.

D

UNDERFLOOR FAN POWERED TERMINAL UNITS



Underfloor Fan Powered Terminal Units

Models: 38S • Unit Sizes 1, 3 and 5

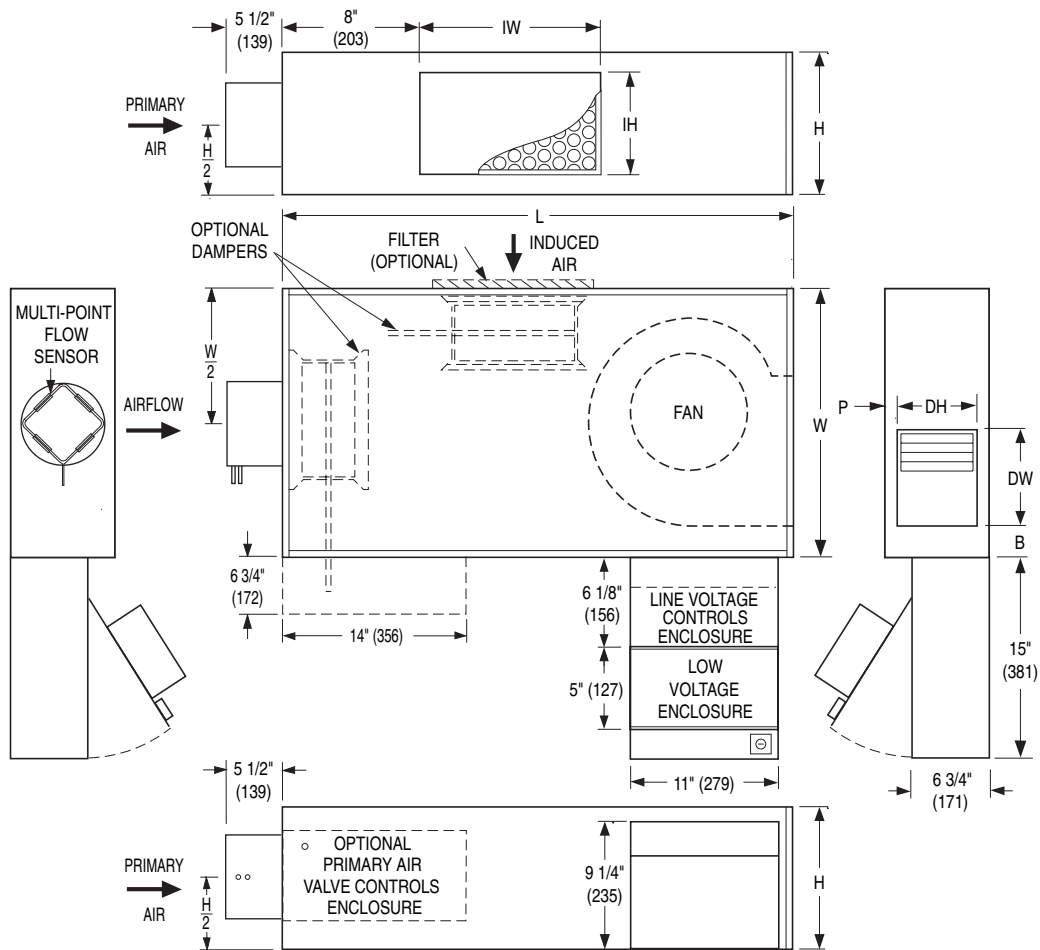

Dimensional Data. Imperial Units (inches)

Unit Size	Inlet Size	W	H	L	B	P	Inlet IW x IH	Outlet Discharge DW x DH	Filter Size
1	4, 5, 6	20	8 1/2	40	2 3/8	29/32	17 x 5 3/4	7 3/16 x 5 15/16	19 x 7
3	6, 8, 10	20	11	40	4 3/8	1 1/2	17 x 8	12 1/4 x 8	19 x 10
5	10,*12,*14*	20	15	44	1 1/4	2	17 x 12	13 1/4 x 11 1/2	20 x 15

Dimensional Data. Metric Units (mm)

Unit Size	Inlet Size	W	H	L	B	P	Inlet IW x IH	Outlet Discharge DW x DH	Filter Size
1	102, 127, 152	508	216	1016	60	23	432 x 146	183 x 151	483 x 178
3	152, 203, 254	508	279	1016	111	38	432 x 203	311 x 203	483 x 254
5	254*,305*,356*	508	381	1118	32	51	432 x 305	337 x 292	508 x 381

* Oval Inlets

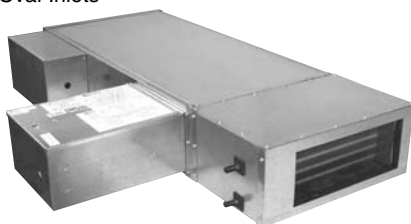

Model 38SW



Model 38SE



ARI Standard 880



A Participating Corporation in the ARI 880 Certification program.

D

UNDERFLOOR FAN POWERED TERMINAL UNITS

Underfloor Fan Powered Terminal Units

Model Series: 38SW and 38SE • Unit Sizes 1, 3 and 5

Hot Water Coil Section

Model 38SW

Available in 1, 2 or 3 row. Coil section installed on unit discharge. Right hand coil connection looking in direction of airflow standard (shown). Left hand is optional (terminals are inverted). Connections must be selected same hand as controls enclosure location.

STANDARD FEATURES:

- Coil section installed on unit discharge.

- Coil (and header on multi-circuit units) is installed in insulated casing for increased thermal efficiency.

- 1/2" (13) copper tubes.
- Aluminum ripple fins.
- Sweat connections: One row 1/2" (13) O.D. male solder. Two and three row 7/8" (22) O.D. male solder.
- Top and bottom access

panels for inspection and coil cleaning.

- Flanged outlet duct connection.

Unit Size	Imperial Units (inches)			Metric Units (mm)		
	Outlet Duct Size C x D	H	J	Outlet Duct Size C x D	H	J
1	14 3/4 x 5 3/4	8 1/2	1	375 x 146	216	25
3	14 3/4 x 8 3/4	11	1 1/8	375 x 222	279	29
5	17 x 11 1/2	15	1 1/2	432 x 292	381	38

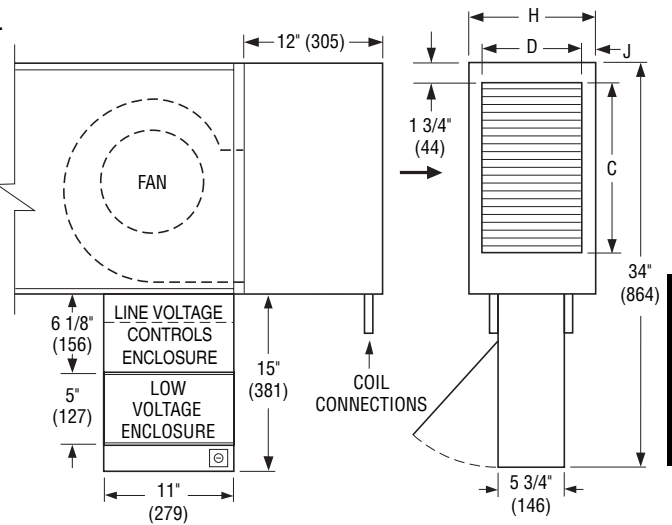

Electric Coil Section

Model: 38SE

STANDARD FEATURES:

- 20 ga. (1.0) galv. steel construction.
- Automatic reset high limit cut-outs (one per element).
- Controls enclosure incorporates a hinged access door opening upstream to help ensure NEC clearance and reduce footprint. FN2 (90° design) is standard.
- Controls mounted as standard on RHS as shown.
- Electric heater installed on unit discharge.
- Flanged outlet duct connection.
- Insulated heater element wrapper.
- Positive pressure airflow switch.

- Single point electric connection for the entire terminal unit.

- Terminal unit w/coil is ETL listed as an assembly.

Std. Supply Volt.(60 Hz):

Single phase:

- 120V • 208V • 220V* • 240V
- 277V • 347V • 380V* • 480V
- 600V

Three phase - delta configuration:

- 208V • 220V* • 240V

Three phase - wye configuration:

- 380V* • 480V • 600V

(Three phase is only available for size 3 & 5 boxes).

* Outside of the U.S.

OPTIONS:

- Class 'A'80/20 Ni./Cr. Wire.
- Door interlock disconnect switch.
- Dust tight construction.
- Left hand configuration.
- Manual reset secondary thermal cut-out.
- Mercury contactors.
- Power circuit fusing.
- Toggle disconnect switch.

Dimensional Data. Imperial Units (inches)

Unit Size	Outlet Discharge F x G	H	N	C	R	S
1	8 1/4 x 5 1/2	8 1/2	9	1 3/8	2	1
3	11 x 7 7/8	11	9	1	1 5/8	1 5/8
5	12 x 8 3/4	15	13 3/4	1	1	4

Dimensional Data. Metric Units (mm)

Unit Size	Outlet Discharge F x G	H	N	C	R	S
1	210 x 140	216	229	35	51	25
3	279 x 200	278	229	25	41	41
5	305 x 222	381	352	25	25	102

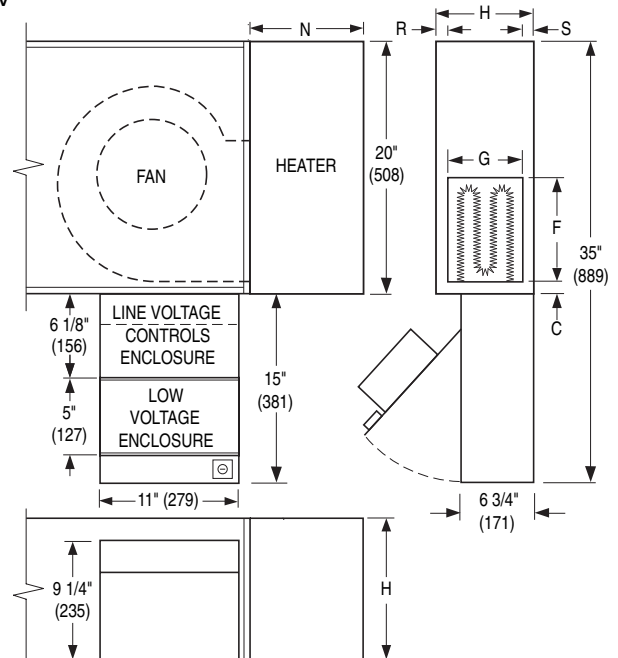

Model Series 38S • Underfloor Fan Powered Terminal Units • Series Flow Performance Data • Fan Curves – Airflow vs. Downstream Static Pressure

ECM "Brushless DC" Motors

Unit Size 1

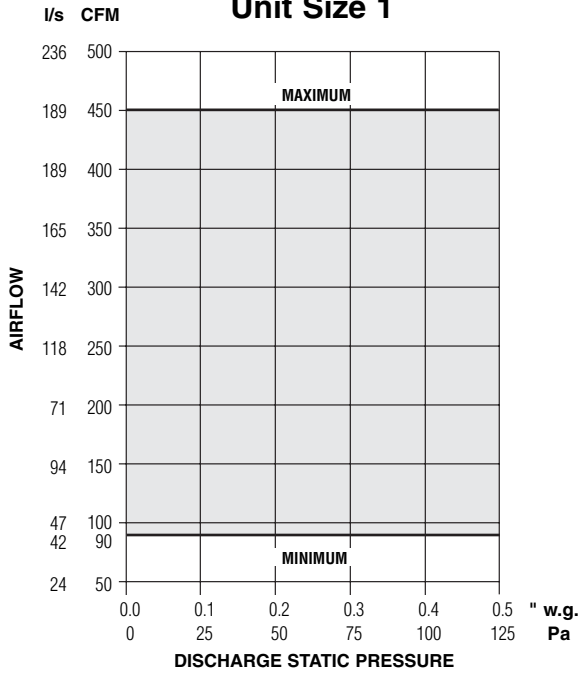

Unit Size 3

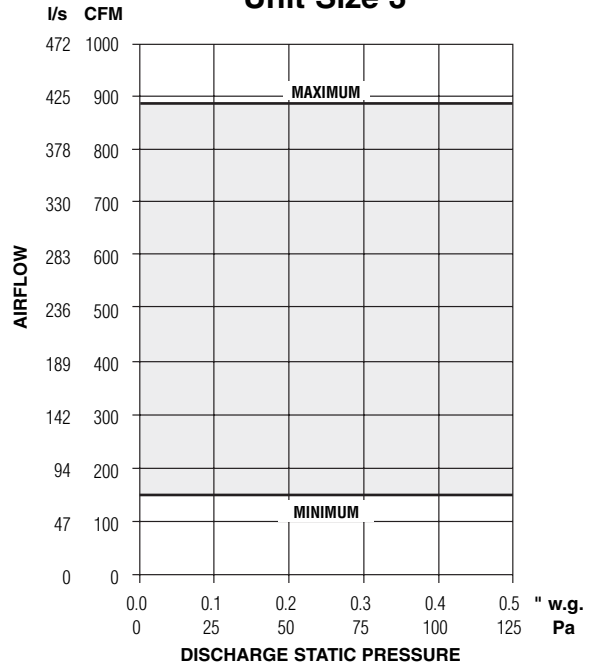

Unit Size 5

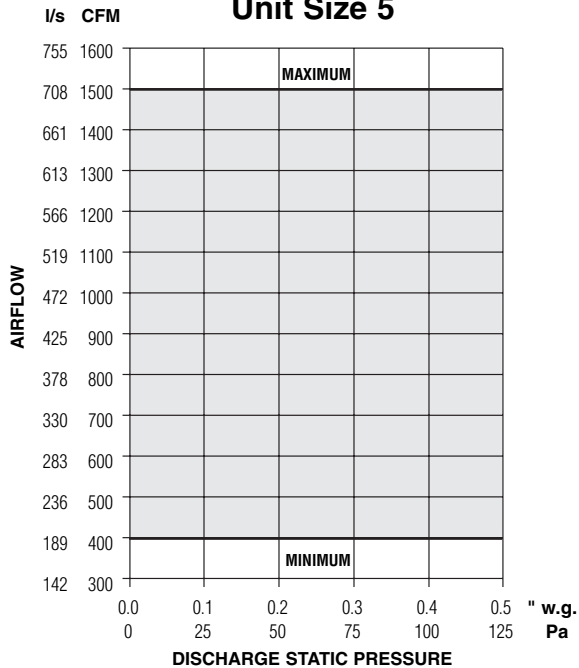

Electrical Data

Unit Size	ECM Motor FLA			
	Voltage	120/1/60	208/240/1/60	277/1/60
1	Watts	277	276	270
	FLA	3.7	1.9	1.9
3	Watts	420	450	410
	FLA	5.8	3.4	2.9
5	Watts	810	830	800
	FLA	12.6	5.7	5.9

FLA = Full load amperage

Notes:

- The fan curves for the ECM motor are unlike those for traditional PSC motors. The ECM motor is constant volume at factory or field set point and airflow does not vary with changing static pressure conditions. The motor compensates for any changes in external static pressure such as filter loading.
- Airflow can be set to operate on horizontal performance line at any point within shaded area using the solid state volume controller provided.
- Fan curves shown are applicable to 120/208/240 and 277 volt, single phase ECM motors. ECM motors, although DC in operation, include a built-in inverter.

D

UNDERFLOOR FAN POWERED TERMINAL UNITS

UNDERFLOOR FAN POWERED TERMINAL UNITS



Model Series 38S • Underfloor Fan Powered Terminal Units • Series Flow Performance Data • Discharge Sound Power Levels

Unit Size	Inlet Size	Airflow cfm /s	Min. inlet ΔPs " w.g. Pa	Fan and 100% Primary Air – Sound Power Octave Bands @ Inlet pressure shown																																									
				Fan Only							Minimum ΔPs							0.5" wg (125Pa)ΔPs							1.0" wg (250Pa)ΔPs							1.5" wg (375Pa)ΔPs							2.0" wg (500Pa)ΔPs						
				2	3	4	5	6	7	2	3	4	5	6	7	2	3	4	5	6	7	2	3	4	5	6	7	2	3	4	5	6	7	2	3	4	5	6	7						
1	4	180 85	0.08 20	48 46 53 52 48 46	47 45 52 51 47 45	47 45 52 50 46 44	47 46 52 51 47 45	47 46 52 51 46 45	47 47 52 51 47 44	140 66	0.05 12	47 43 50 48 44 42	45 43 49 47 43 41	45 43 49 47 43 41	45 44 49 47 43 41	46 43 49 47 43 41	46 44 49 48 43 41	90 42	0.05 12	45 39 47 43 40 37	43 39 46 42 39 36	42 39 46 42 39 36	43 41 46 43 39 37	44 40 46 43 39 37	43 41 46 43 39 36	40 19	0.05 12	43 36 43 39 35 32	41 36 42 38 34 32	40 36 42 38 34 31	41 38 43 39 35 32	42 37 43 39 35 32	41 38 43 39 35 32												
		5	260 123	0.08 20	52 52 59 59 55 53	50 51 58 58 54 52	50 51 57 57 53 52	50 51 57 57 53 52	51 51 57 57 53 52	200 94	0.05 12	49 47 54 54 49 47	48 47 54 52 48 47	48 47 53 52 48 46	48 47 53 52 48 46	48 47 53 52 48 46	48 48 53 52 48 45	140 66	0.05 12	47 43 50 48 44 42	45 43 49 47 43 41	45 43 49 47 43 41	45 44 49 47 43 41	46 43 49 47 43 41	46 44 49 48 43 41	70 33	0.05 12	44 38 45 41 38 35	42 38 44 40 37 35	42 38 44 41 37 34	42 39 45 42 38 35	43 39 45 42 38 35	42 40 45 42 38 35												
			6	375 177	0.05 12	58 60 66 69 64 63	56 58 65 68 63 62	56 59 64 67 63 62	56 57 64 66 61 61	56 58 62 66 61 61	300 142	0.05 12	53 55 63 64 59 58	52 54 62 62 58 57	52 54 61 61 58 57	52 54 61 61 57 56	53 54 61 61 57 56	53 54 61 61 57 52	200 94	0.05 12	47 47 56 54 50 49	46 47 56 53 50 48	46 46 54 52 49 47	47 47 55 52 49 47	47 46 55 52 49 47	48 48 55 53 49 47	100 47	0.05 12	44 40 46 44 40 37	44 40 45 43 39 36	44 41 45 43 39 36	44 41 46 44 39 36	45 41 46 44 39 37	44 42 46 44 40 37											
				6	325 153	0.08 20	45 43 44 41 34 34	45 42 44 40 34 34	46 44 44 40 36 34	47 46 45 41 38 35	48 46 47 42 38 35	290 137	0.08 20	44 41 43 39 33 32	44 41 43 39 32 32	45 43 43 39 34 32	46 45 44 40 37 33	47 45 46 40 37 34	49 44 45 40 37 34	200 94	0.05 12	42 38 39 35 28 28	41 37 39 35 28 28	43 40 40 35 30 28	44 42 41 36 34 29	44 42 43 37 33 30	47 41 42 36 34 30	90 42	0.05 12	38 34 35 30 23 23	38 33 35 30 22 23	40 37 36 31 25 23	42 39 38 32 29 25	42 39 40 32 29 25	44 37 38 32 30 25										
	8				575 271	0.08 20	52 52 53 52 47 45	52 52 53 51 47 46	52 53 53 51 47 45	53 53 54 51 48 46	54 54 55 52 48 46	500 236	0.08 20	50 49 51 48 43 42	50 49 51 48 43 42	50 50 51 48 44 42	51 51 51 48 45 42	52 52 52 49 45 43	54 52 52 49 46 43	350 165	0.05 12	46 44 45 42 36 35	45 43 45 41 35 35	46 45 45 41 37 35	48 47 46 42 39 36	48 47 48 43 39 36	50 46 47 43 40 36	150 71	0.05 12	40 36 38 33 26 26	40 36 37 33 25 25	41 39 38 33 28 26	43 41 40 34 32 27	43 41 41 35 31 28	46 39 40 34 32 27										
		10			900 425	0.08 20	62 64 65 65 62 60	62 64 65 64 61 61	61 64 65 64 61 60	61 63 64 63 60 59	62 64 64 64 60 60	800 378	0.05 12	59 61 61 62 58 56	58 61 62 61 58 57	58 59 61 60 56 55	57 59 60 59 56 55	59 61 61 60 57 56	59 61 61 60 56 55	550 260	0.05 12	50 53 55 54 50 46	49 53 55 53 49 46	50 53 54 52 48 45	52 54 55 53 49 46	54 54 56 53 49 46	54 55 55 53 49 46	250 118	0.05 12	44 39 40 36 29 30	44 39 40 35 28 30	45 42 41 36 31 30	46 44 42 37 35 31	45 43 44 37 34 32	49 42 43 37 35 31										
			10		1100 519	0.08 20	63 65 66 62 58 59	54 55 58 55 50 52	55 57 59 55 51 52	56 57 59 56 51 53	57 58 59 56 52 53	900 425	0.08 20	59 60 61 58 54 54	49 50 56 51 46 47	53 53 56 52 48 48	53 53 56 52 48 48	55 53 57 53 49 49	56 55 57 53 49 49	700 330	0.05 12	52 53 54 52 45 44	46 45 49 46 40 38	49 48 51 47 41 39	49 49 51 47 41 39	52 50 52 48 42 40	51 51 53 48 43 41	300 142	0.05 12	45 42 45 42 34 31	44 41 44 40 33 30	45 41 44 41 33 30	45 42 45 41 34 30	45 42 44 41 34 31	46 42 45 41 34 32										
				12*	1500 708	0.08 20	71 71 71 68 64 66	61 62 65 62 58 59	62 63 65 62 58 59	63 63 65 62 58 60	62 61 66 63 59 60	1200 566	0.08 20	64 66 66 63 59 60	55 55 59 56 51 53	56 57 60 56 52 53	57 57 60 57 52 54	57 58 60 57 53 54	58 59 61 57 53 54	900 425	0.08 20	59 60 61 58 54 54	49 50 56 51 46 47	53 53 56 52 48 48	53 53 56 52 48 48	55 53 57 53 49 49	56 55 57 53 49 49	600 283	0.06 15	51 50 53 49 44 43	45 45 48 44 39 37	47 46 49 45 39 37	48 47 49 45 39 37	51 48 50 46 40 38	50 49 51 46 41 39										

* Flat oval inlet

ARI Certification Rating Points

Unit Size	Inlet Size	Fan cfm	Fan† Watts	Min ΔPs	Fan Only *						
					2	3	4	5	6	7	
1	4	180	277	0.08	47	46	52	51	46	45	
	5	260	277	0.08	51	51	57	57	53	52	
	6	375	277	0.05	56	58	62	66	61	61	
3	6	325	450	0.08	48	46	47	42	38	35	
	8	575	450	0.08	54	54	55	52	48	46	
	10	900	450	0.08	62	64	64	64	60	60	
5	10	1100	1080	0.08	57	58	59	56	52	53	
	12	1500	1080	0.08	62	61	66	63	59	60	

* Primary air valve is closed and therefore primary cfm is zero.

Performance Notes:

- Discharge (external) static pressure is 0.25" w.g. (63 Pa) in all cases. It is the difference (ΔPs) in static pressure from terminal discharge to the room.
- Discharge sound power is the noise emitted from the unit discharge into the downstream duct.
- Sound power levels are in decibels, dB re 10⁻¹² watts.
- All sound data listed by octave bands is raw data without any corrections for room absorption or duct attenuation.

- Min. inlet ΔPs is the minimum operating pressure of the primary air valve section.
- Data derived from independent tests conducted in accordance with ANSI/ASHRAE Standard 130-1996 and ARI Standard 880-98.



ARI Standard 880
A Participating Corporation in the ARI 880 Certification program.

UNDERFLOOR FAN POWERED TERMINAL UNITS

Model Series 38S • Underfloor Fan Powered Terminal Units • Series Flow Performance Data • Radiated Sound Power Levels

Unit Size	Inlet Size	Airflow cfm l/s	Min. inlet ΔPs " w.g. Pa		Fan and 100% Primary Air – Sound Power Octave Bands @ Inlet pressure shown																																									
					Fan Only							Minimum ΔPs							0.5" wg (125Pa)ΔPs							1.0" wg (250Pa)ΔPs							1.5" wg (375Pa)ΔPs							2.0" wg (500Pa)ΔPs						
					2	3	4	5	6	7	2	3	4	5	6	7	2	3	4	5	6	7	2	3	4	5	6	7	2	3	4	5	6	7	2	3	4	5	6	7						
1	4	180 85	0.08 20	51 43 40 35 31 28	52 42 40 35 32 28	52 44 41 39 36 32	52 46 46 46 42 38	53 47 47 48 45 43	54 47 47 49 47 47	140 66	0.05 12	49 40 38 32 29 26	50 40 37 32 30 26	51 42 39 37 34 30	50 43 44 45 41 37	50 44 45 48 44 42	52 44 45 48 46 45	90 42	0.05 12	47 37 35 29 26 24	48 36 34 29 28 24	49 39 36 34 33 28	47 40 42 44 40 35	48 41 43 47 44 40	49 40 42 46 45 43	40 19	0.05 12	45 34 32 26 24 21	46 33 31 25 26 22	47 36 34 32 31 27	45 37 40 44 38 33	45 38 40 46 43 38	46 37 39 45 44 42													
		5	260 123	0.08 20	55 48 45 40 35 32	55 48 45 40 36 31	55 49 46 42 39 35	56 50 49 47 44 41	57 51 50 49 46 46	58 53 52 51 49 50	200 94	0.05 12	52 44 41 36 32 29	52 44 41 36 33 29	53 45 42 39 37 33	53 47 47 46 42 39	54 48 48 48 45 44	55 49 49 49 47 48	140 66	0.05 12	49 40 38 32 29 26	50 40 37 32 30 26	51 42 39 37 34 30	50 43 44 45 41 37	50 44 45 48 44 42	52 44 45 48 46 45	70 33	0.05 12	46 36 33 28 25 23	47 35 33 27 27 23	48 38 35 33 32 28	46 39 41 44 39 34	47 40 42 47 43 39	48 39 41 46 45 43												
			6	375 177	0.05 12	60 56 51 48 41 38	60 55 52 48 42 36	60 55 52 48 43 40	62 57 54 50 47 46	63 58 56 52 49 49	64 62 59 56 52 54	300 142	0.05 12	56 51 49 43 37 34	55 50 48 42 37 33	56 51 48 44 40 37	58 53 50 47 44 42	59 54 52 49 47 47	60 56 53 51 49 52	200 94	0.05 12	52 44 42 36 33 29	50 44 42 36 33 29	51 46 43 39 37 32	53 48 46 43 43 40	54 48 48 46 45 44	54 51 50 48 47 47	100 47	0.05 12	47 38 35 30 27 24	50 37 34 30 29 24	51 39 37 35 33 29	48 40 43 47 40 35	48 42 43 49 44 40	50 40 42 48 46 44											
				6	325 153	0.08 20	48 48 49 42 33 26	48 48 49 43 34 26	54 51 50 49 50 50	56 52 53 53 53 57	53 52 54 54 55 60	54 53 55 55 56 61	290 137	0.08 20	47 47 48 41 32 25	47 47 49 42 33 25	53 51 50 49 51 51	56 51 53 52 53 57	52 51 53 54 55 60	53 52 55 55 56 62	200 94	0.05 12	44 45 46 39 30 23	44 45 47 40 31 23	51 49 48 47 51 52	54 50 52 52 54 58	50 49 52 53 55 61	51 50 54 54 55 62	90 42	0.05 12	40 42 44 36 27 21	41 43 45 37 28 20	49 47 46 46 51 53	53 48 51 51 54 59	48 47 50 52 55 61	48 47 52 52 55 62										
	8				575 271	0.08 20	56 54 53 49 40 31	56 53 53 49 40 32	59 56 55 52 49 47	60 56 56 55 53 54	59 57 58 57 55 58	60 58 59 59 57 61	500 236	0.08 20	53 52 52 47 38 29	54 52 52 47 38 30	57 54 53 51 50 48	59 55 56 54 53 55	57 55 57 56 55 59	58 57 58 58 57 61	350 165	0.05 12	49 48 49 43 34 26	49 48 50 43 34 27	54 52 51 49 50 50	57 52 54 53 53 56	54 52 54 55 55 60	54 53 56 56 56 61	150 71	0.05 12	42 43 45 38 29 22	43 44 46 39 30 22	50 48 48 47 51 52	54 49 51 51 54 59	49 48 51 52 55 61	50 49 53 53 55 62										
		10			900 425	0.05 12	66 62 59 56 48 38	66 60 58 55 47 40	65 60 59 55 48 43	64 61 60 56 51 49	67 63 62 60 55 56	68 65 63 63 57 59	800 378	0.05 12	64 59 57 54 46 36	64 59 58 54 46 38	63 59 59 54 47 43	63 60 59 56 51 50	64 62 61 60 54 55	65 64 62 62 58 61	550 260	0.05 12	55 52 53 49 40 30	56 53 54 50 41 32	60 57 56 55 53 53	60 59 58 57 56 60	60 59 60 59 57 62	59 59 60 60 57 63	250 118	0.05 12	46 46 47 40 31 24	46 46 48 40 31 24	52 49 48 47 49 48	55 49 52 51 52 55	51 49 52 52 54 58	52 50 53 54 55 60										
			10		1100 519	0.08 20	63 65 65 62 58 59	51 56 60 57 52 54	57 58 61 57 53 54	58 58 61 58 53 55	58 59 61 58 54 55	59 60 62 58 54 55	900 425	0.08 20	64 56 56 52 43 38	53 49 52 46 38 55	58 54 54 50 49 46	59 57 57 54 57 54	62 59 60 57 60 61	63 64 62 59 62 64	700 330	0.05 12	58 50 52 48 39 34	52 47 47 42 34 31	54 50 50 48 48 44	57 55 55 52 56 52	59 58 58 55 59 58	60 60 60 57 61 62	300 142	0.05 12	51 43 44 39 30 27	46 40 40 35 28 25	48 46 45 44 42 38	50 48 48 47 50 47	50 50 51 50 54 53	50 50 52 52 57 57										
				12*	1500 708	0.08 20	75 67 65 61 53 50	64 59 58 54 47 44	66 61 60 55 51 50	68 63 61 58 56 56	69 63 64 60 59 62	68 67 65 62 61 65	1200 566	0.08 20	64 66 66 63 59 60	55 55 59 56 51 53	56 57 60 56 52 53	57 57 60 57 52 54	57 58 60 57 53 54	58 59 61 57 53 54	900 425	0.08 20	64 56 56 52 43 38	52 48 50 44 36 32	57 53 52 48 47 44	58 56 55 52 55 52	61 58 58 55 58 59	62 63 60 57 60 62	600 283	0.06 15	57 49 50 46 37 32	51 46 45 40 32 29	53 49 48 46 46 42	56 54 53 50 54 50	58 57 56 53 57 56	59 59 58 55 59 60										

* Flat oval inlet

ARI Certification Rating Points

Unit Size	Inlet Size	Pri. cfm	Fan cfm	Fan† Watts	Min ΔPs	Fan Only *							Fan & Primary CFM Shown @ 1.5" w.g.						
						2	3	4	5	6	7	2	3	4	5	6	7		
1	4	180	180	277	0.08	51	43	40	35	31	28	53	47	47	48	45	43		
	5	260	260	277	0.08	55	48	45	40	35	32	57	51	50	49	46	46		
	6	375	375	277	0.05	60	56	51	48	41	38	63	58	56	52	49	49		
3	6	325	325	450	0.08	48	48	49	42	33	26	53	52	54	54	53	60		
	8	575	575	450	0.08	56	54	53	49	40	31	59	57	58	57	55	58		
	10	900	900	450	0.05	66	62	59	56	48	38	67	63	62	60	55	56		
5	10	1100	1100	1080	0.08	63	65	65	62	58	59	58	59	61	58	54	55		
	12	1500	1400	1080	0.08	75	67	65	61	53	50	69	63	64	60	59	62		

* Primary air valve is closed and therefore primary cfm is zero.

Performance Notes:

1. Discharge (external) static pressure is 0.25" w.g. (63 Pa) in all cases. It is the difference (ΔPs) in static pressure from terminal discharge to the room.
2. Radiated sound power is the breakout noise transmitted through the unit casing walls.
3. Sound power levels are in decibels, dB re 10⁻¹² watts.
4. All sound data listed by octave bands is raw data without any corrections for room absorption or duct attenuation.

5. Min. inlet ΔPs is the minimum operating pressure of the primary air valve section.
6. Data derived from independent tests conducted in accordance with ANSI/ASHRAE Standard 130-1996 and ARI Standard 880-98.



ARI Standard 880

A Participating Corporation in the ARI 880 Certification program.

D UNDERFLOOR FAN POWERED TERMINAL UNITS

Model Series 38SW • Underfloor Fan Powered Terminal Units • Series Flow Performance Data • Hot Water Coils • Unit Size 1

1 Row (single circuit)

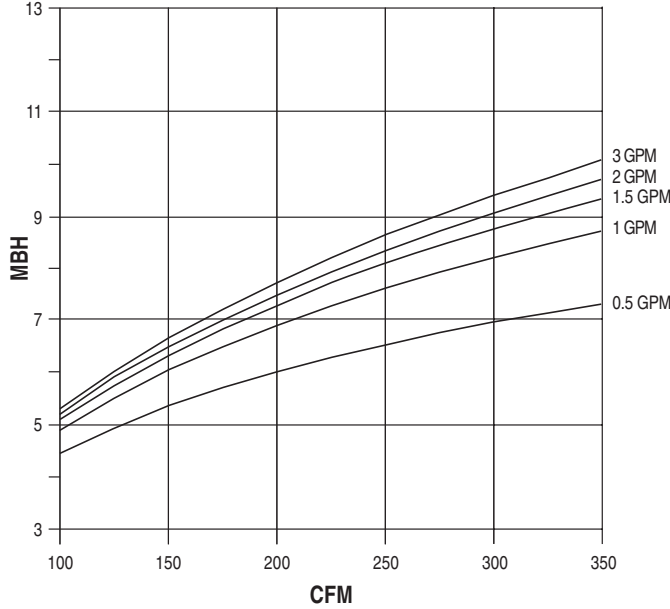

2 Row (multi-circuit)

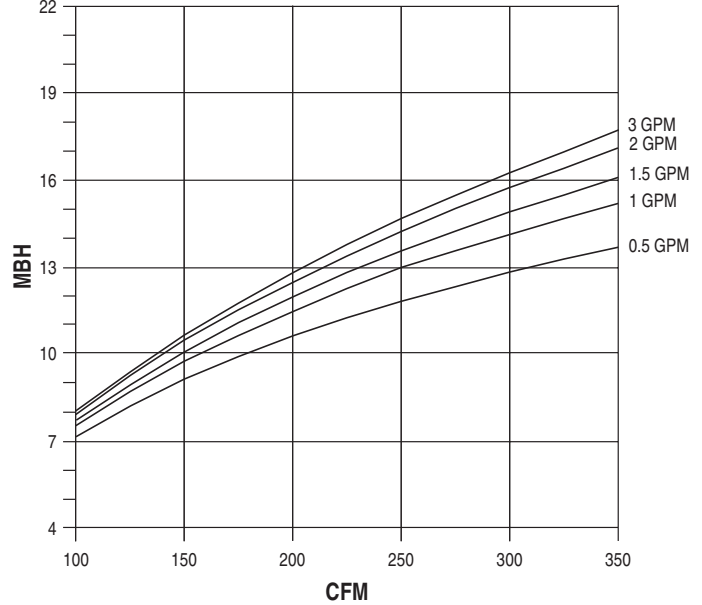

3 Row (multi-circuit)

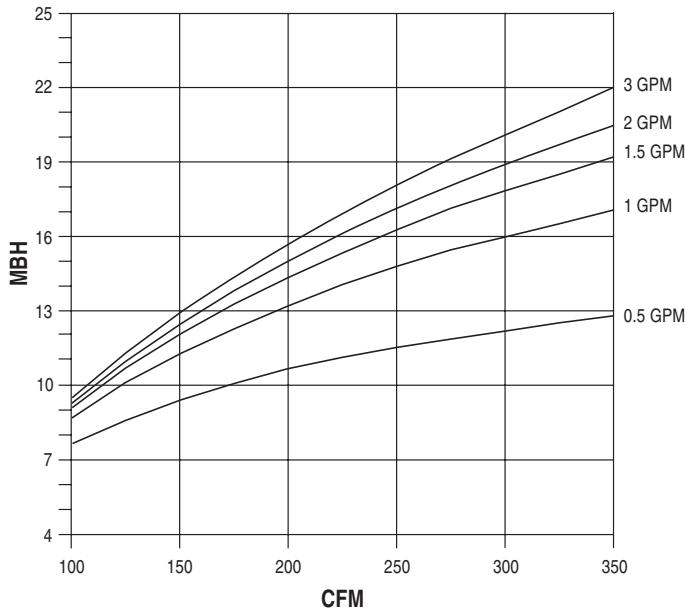

Water Pressure Drop

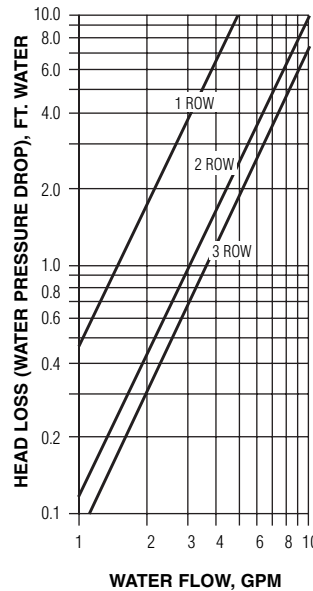

Air Pressure Drop

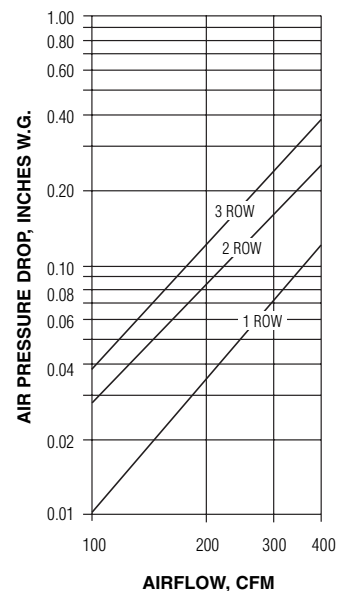

Notes:

- Capacities are in Mbh (thousands of Btu per hour).
- Mbh values are based on a ΔT (temperature difference) of 110°F between entering air and entering water. For other ΔT 's; multiply the Mbh values by the factors below.
- Air Temperature Rise. $ATR = 927 \times \frac{Mbh}{cfm}$
- Water Temp. Drop. $WTD = 2.04 \times \frac{Mbh}{GPM}$
- Connections: 1 Row 1/2" (13), 2 and 3 Row 7/8" (22); O.D. male solder.

Correction factors at other entering conditions:

ΔT °F	50	60	70	80	90	100	110	120	130	140	150
Factor	.455	.545	.636	.727	.818	.909	1.00	1.09	1.18	1.27	1.36

Altitude Correction Factors:

Altitude (ft.)	Sensible Heat Factor
0	1.00
2000	0.94
3000	0.90
4000	0.87
5000	0.84
6000	0.81
7000	0.78

D

UNDERFLOOR FAN POWERED TERMINAL UNITS

Model Series 38SW • Underfloor Fan Powered Terminal Units • Series Flow Performance Data • Hot Water Coils • Unit Size 3

1 Row (single circuit)

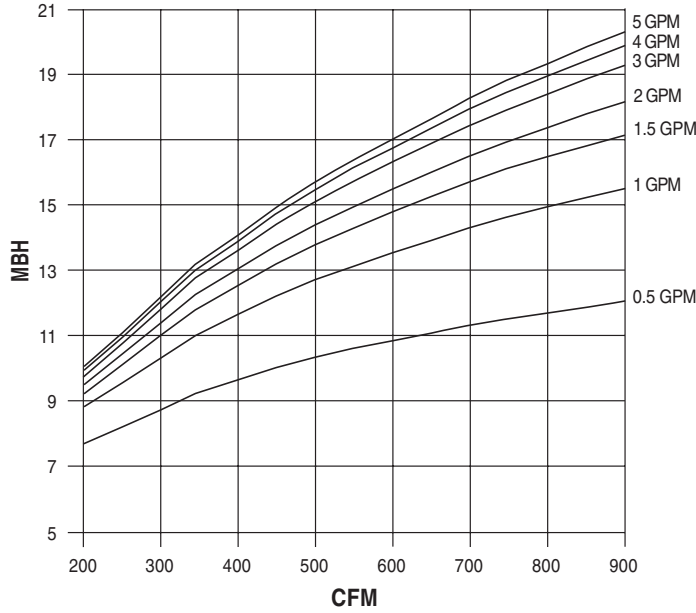

2 Row (multi-circuit)

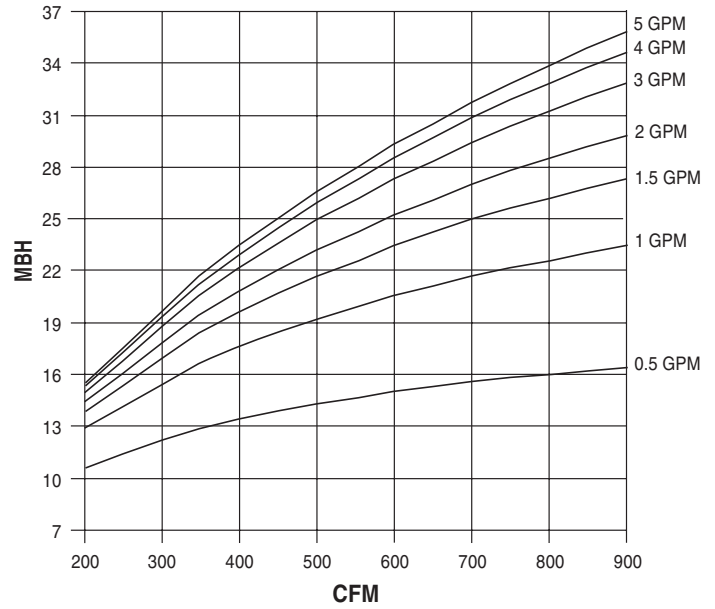

3 Row (multi-circuit)

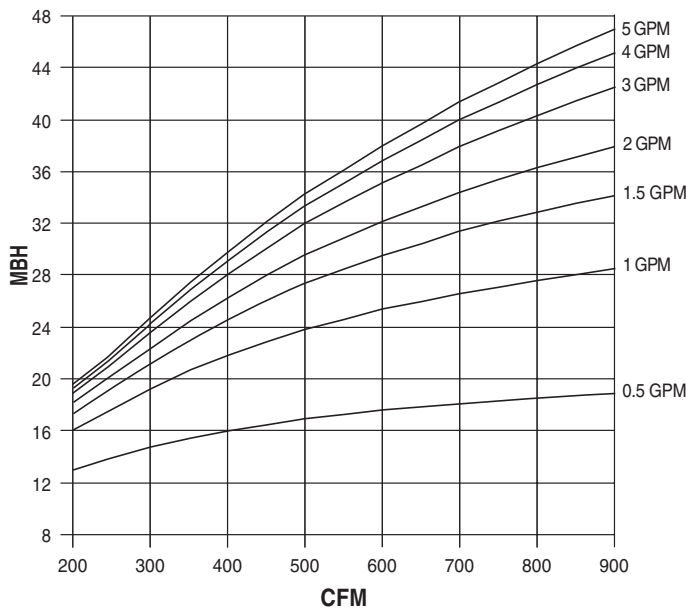

Water Pressure Drop

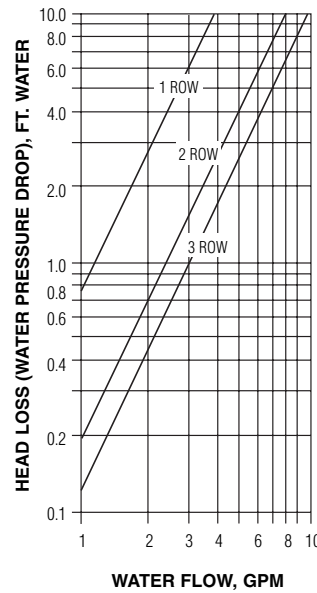

Air Pressure Drop

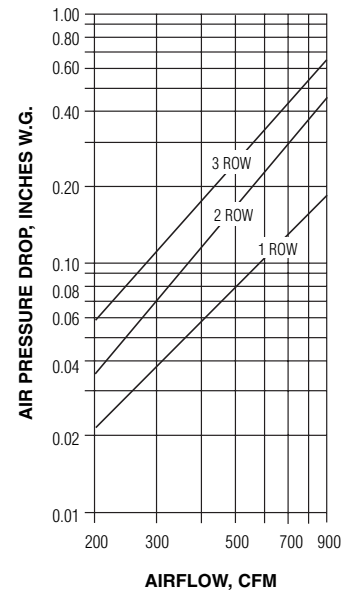

Notes:

- Capacities are in Mbh (thousands of Btu per hour).
- Mbh values are based on a ΔT (temperature difference) of 110°F between entering air and entering water. For other ΔT 's; multiply the Mbh values by the factors below.
- Air Temperature Rise. $ATR = 927 \times \frac{Mbh}{cfm}$
- Water Temp. Drop. $WTD = 2.04 \times \frac{Mbh}{GPM}$
- Connections: 1 Row 1/2" (13), 2 and 3 Row 7/8" (22); O.D. male solder.

Correction factors at other entering conditions:

ΔT °F	50	60	70	80	90	100	110	120	130	140	150
Factor	.455	.545	.636	.727	.818	.909	1.00	1.09	1.18	1.27	1.36

Altitude Correction Factors:

Altitude (ft.)	Sensible Heat Factor
0	1.00
2000	0.94
3000	0.90
4000	0.87
5000	0.84
6000	0.81
7000	0.78

D

UNDERFLOOR FAN POWERED TERMINAL UNITS

Model Series 38SW • Underfloor Fan Powered Terminal Units • Series Flow Performance Data • Hot Water Coils • Unit Size 5

1 Row (single circuit)

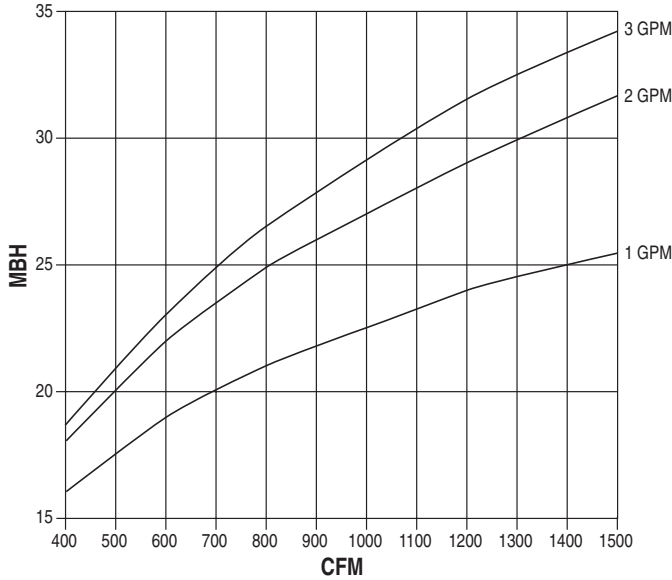

2 Row (multi-circuit)

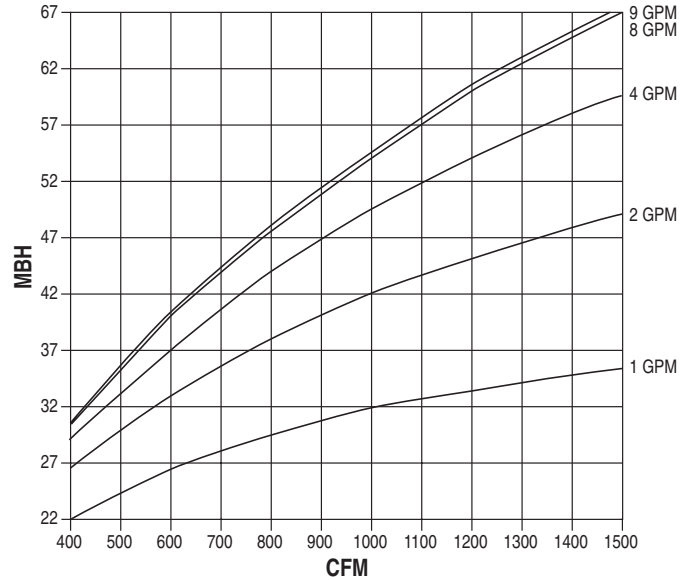

Water Pressure Drop

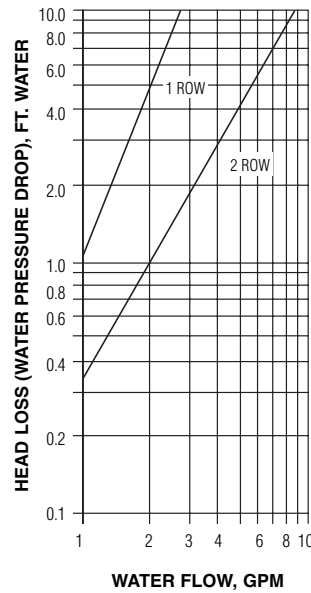

Air Pressure Drop

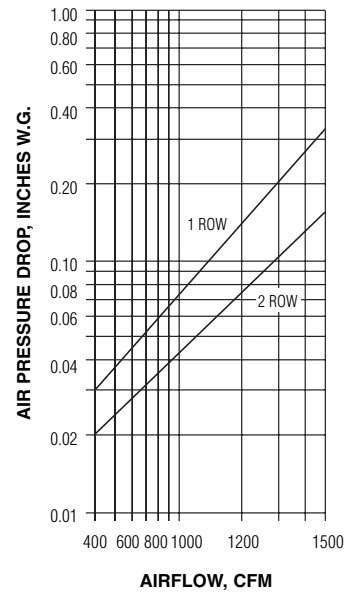

Notes:

- Capacities are in Mbh (thousands of Btu per hour).
- Mbh values are based on a ΔT (temperature difference) of 110°F between entering air and entering water. For other ΔT 's; multiply the Mbh values by the factors below.
- Air Temperature Rise. $ATR = 927 \times \frac{\text{Mbh}}{\text{cfm}}$
- Water Temp. Drop. $WTD = 2.04 \times \frac{\text{Mbh}}{\text{GPM}}$
- Connections: 1 Row 1/2" (13), 2 and 3 Row 7/8" (22); O.D. male solder.

Correction factors at other entering conditions:

ΔT °F	50	60	70	80	90	100	110	120	130	140	150
Factor	.455	.545	.636	.727	.818	.909	1.00	1.09	1.18	1.27	1.36

Altitude Correction Factors:

Altitude (ft.)	Sensible Heat Factor
0	1.00
2000	0.94
3000	0.90
4000	0.87
5000	0.84
6000	0.81
7000	0.78

D

UNDERFLOOR FAN POWERED TERMINAL UNITS

Electric Heating Coils • Construction Features, Selection and Capacities

Nailor Electric Coils are tested with the fan terminal in accordance with UL Standard 1995 and meet all requirements of the National Electric Code and CSA. Units are listed and labeled by the ETL Testing Laboratory as a total package. All controls are enclosed in a NEMA 1 electrical enclosure on the side of the fan package for easy access.

All wiring for the motor and heater terminates in the enclosure for single point electrical connection in the field. Each unit is supplied with a wiring diagram. Note: NEC requires a means to disconnect the heater power supply within sight or on the terminal.

Standard Features Include:

- Automatic reset high limit thermal cut-outs.
- Nickel-chrome heating elements.
- Magnetic contactors per stage on terminals with DDC or analog electronic controls.
- P.E. switch per stage to carry load or pilot duty with magnetic contactors as required with pneumatic control.
- Positive pressure airflow safety switch or CT relay.
- Fan relay for DDC fan coils.
- Control voltage transformer (Class 2) for DDC or analog electronic fan coils.

Optional Accessories:

- Toggle disconnect switch.
- Door interlocking disconnect switch.
- Mercury contactors.
- Power circuit fusing.
- Dust tight control enclosure.
- Class 'A' 80/20 nickel/chrome element wire.
- Manual reset high limits.
- SCR Control.



Tested and approved to the following standards:

ANSI/UL 1996, 1st. ed.
CSA C22.2 No. 155-M1986.
UL 1995

SCR Control Option:

The SCR (Thyrister) option provides infinite solid state heater control using a proportional signal (0 – 10 Vdc or 4 – 20 mA). This option may be specified compatible with analog electronic or digital (DDC) controls.

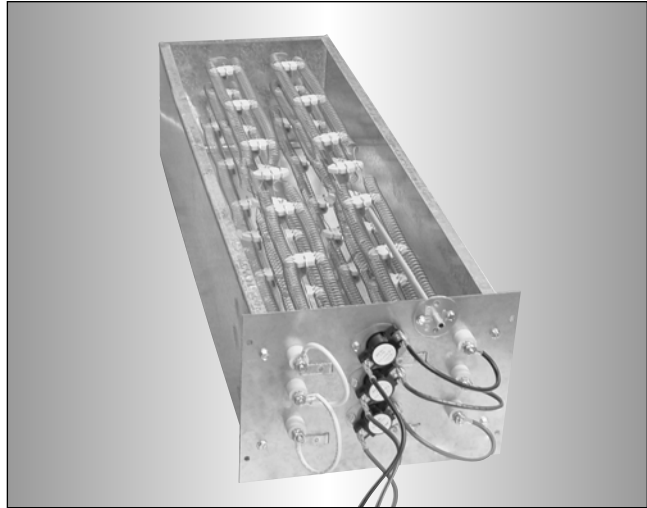

Time proportional control of the electric heater provides superior comfort and energy savings. The SCR controller modulates the heater to supply the exact amount of heat based upon the zone requirement. Room set points are maintained more accurately, undershoot and overshoot as associated with staged heat are eliminated, reducing operation costs.

SCR controllers provide silent operation, as mechanical staged contactors are eliminated. Zero cross switching of the thyristor prevents electrical noise.

Recommended Selection:

The table below is a quick reference guide, to illustrate the relationship between electrical power supply, heater capacity in kilowatts and fan coil unit sizes that are available.

- Pneumatic and digital control terminals are available with up to 3 stages of heat. Analog electronic control terminals are available with 1 or 2 stages of heat only. A minimum of 0.5 kW per stage is required.
- Voltage and kilowatt ratings are sized so as not to exceed 48 amps, in order to avoid the NEC code requirement for circuit fusing.
- A minimum airflow of 70 cfm (33 l/s) per kW is required for any given fan coils in order to avoid possible nuisance tripping of the thermal cut-outs.
- Discharge air temperature should not exceed 120°F (49°C).

Model Series	Unit Size	Electric Heat Maximum Kilowatts												
		120V 1 Ph	208/220/240V 1 Ph	277V 1 Ph	347V 1Ph	480V 1 Ph	600V 1Ph (120V Fan)	600V 1Ph (240/277V Fan)	208V 3Ph	220/240V 3Ph	380V 3Ph	480V 3Ph	600V (120V Fan)	600V (240/277V Fan)
38S	1	4.8	5	5	5	5	5	5	—	—	—	—	—	—
	3	4.8	8	11.5	13	14	14	14	9	9.5	8	10	12	12
	5	5.4	9.3	12.4	15.6	21.6	21.6	21.6	10.8	10.8	11.7	12.4	14.1	14.1

D UNDERFLOOR FAN POWERED TERMINAL UNITS

Electric Heating Coils • Application Guidelines

Discharge Air Temperature

When considering the capacity and airflow for the heater, discharge air temperature can be an important factor. Rooms use different types of diffusers, and they are intended to perform different functions. Slots that blend the air at the glass and set up air curtains within the room, must be able to blow the air very low in the room. Hot air will be too buoyant to be effective in this case. Discharge air temperatures for this application should be in the 85 – 90°F (29 – 32°C) range.

Diffusers in the center of the room blend their discharge air as it crosses the ceiling. Discharge air temperatures in this application can be as high as 105°F (41°C) and still be effective. However, if the return air grilles are in the discharge air pattern, the warm air will be returned to the plenum before it heats the room. Again, the air temperature needs to be blended down to an acceptable temperature that can be forced down into the occupied space by the time the air gets to the walls. Discharging warm air into the room at temperatures above 105°F (41°C) usually will set up stratification layers and will not keep the occupants warm if there is a ceiling return because only the top 12" – 24" (300 – 600 mm) of the room will be heated.

The maximum approved discharge air temperature for any Nailor Fan Powered VAV Terminal Unit with supplemental heat is 120°F (49°C). No heater should be applied to exceed this temperature.

Electric Heater Selection

To properly select an electric heater, three things must be determined: the heat requirement for the room, the entering air temperature and the desired discharge air temperature. The heat requirement for the room is the sum of the heat loss calculation and the amount of heat required to raise the entering air temperature to the desired room temperature. Usually, the second item is small compared to the first for fan powered terminal units in a return air plenum. Mbh can be converted to kW by using the chart or by calculation. There are 3413 Btus in 1 kW. If using the chart, find the Mbh on the left scale, then move horizontally to the right and read kW.

Next, the desired discharge air temperature should be ascertained. This will depend on the type of diffusers that are in the room.

The desired heating airflow for the room can then be calculated using the following equation:

$$\text{cfm} = \frac{\text{kW} \times 3160}{\Delta T \text{ (discharge air temp} - \text{inlet air temp.) } ^\circ\text{F}}$$

Assuming 70°F (21°C) supply air temperature to the heater, the room airflow can be selected directly from the chart. Start at the left at the design kW. Move horizontally to the desired discharge air temperature. Then, move vertically down to the cfm at the bottom of the chart.

The kW can be selected directly from the chart. Start at the bottom with the design cfm into the room. Move vertically up to the line that represents the desired discharge air temperature. Then, move left to the kW.

The discharge air temperature can also be selected directly from the chart. Start at the bottom with the design cfm into the room. Move to the left side of the chart and find the design kW. Move horizontally and vertically into the chart until the lines intersect. The intersection will be the desired discharge air temperature. Interpolation between the curves is linear.

Heater Selection Chart

Assuming 70°F inlet air temperature at heater.

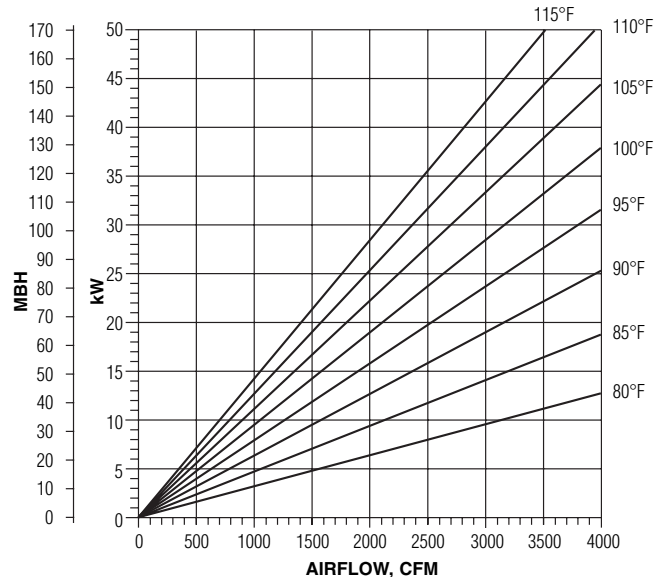

Diagonal lines are constant output temperature.

Controls • General Information

For a description of individual control components; see the controls overview section of the Nailor VAV Terminal Units Catalog.

Analog Electronic

The analog electronic controls provide pressure independent control. The components are matched and calibrated and provide regulated airflow in response to the electronic room thermostat, which is furnished as a part of the control package. Minimum and maximum airflow settings are adjusted at the thermostat, using a digital voltmeter. It is not necessary to adjust flow setting at the terminal in the ceiling space.

The new range of Nailor analog electronic controls utilize the 'Diamond Flow' multi-point averaging sensor as standard for accurate flow measurement.

The electronic thermostat has a fixed 2°F proportional band regardless of minimum or maximum velocity set points and provides a linear reset function. The thermostat has a built-in thermometer and set point indicator. The electronic controller/actuator features an on-board flow transducer.

Electric actuators are not spring return devices (there is no normally open or normally closed action). If there is a loss of power to the terminal, the damper will remain in the position it was in at the time of power failure. All electric components use low voltage (24 volt) controls. A step down transformer is provided as standard.

Direct Digital Controls

Nailor Industries Fan Powered Terminals are generic in nature and compatible with all DDC controls currently available.

Nailor can supply and mount its own 'Diamond Flow' multi-point averaging flow sensor.

Controls may be factory mounted and wired by **Nailor** or field installed by the controls contractor.

A 24 volt Class 2 control transformer and fan relay are provided by Nailor as standard on all fan powered terminals intended for use with digital controls.

Control Operation • Underfloor Fan Powered Terminal Units • Series Flow

Pressure Independent

Analog Electronic

Occupied Cycle

1. The series terminal fan is directly or indirectly interlocked and energized before or when the central system starts up.

Nailor recommends that the terminal fan is indirectly interlocked by means of an airflow switch (optional) which senses primary air pressure at the inlet. Upon central system start up, the fan in the terminal is automatically energized.

2. On a rise in room temperature, the thermostat sends a signal to increase the flow of cold primary air.

3. As more cold air is supplied to the fan section, less warm air is induced from the occupied space or underfloor plenum.

4. When the room temperature exceeds the set point by 2°F or more, cold airflow is maintained at the maximum setting. The maximum setting is the same as the total fan volume setting.

5. On a decrease in room temperature, the thermostat sends a signal to decrease the flow of cold primary air.

6. As less cold air is supplied to the fan section, more warm air is induced from the occupied space or underfloor plenum.

7. When the room temperature and thermostat output signal reach the thermostat set point, the cold airflow is at its minimum limit (usually zero) and the fan is supplying the maximum volume of induced air.

8. If room temperature continues to drop, an optional heating coil may be energized.

9. When the optional airflow switch is supplied, and the central system is turned off (night-time or weekend), the series terminal fan is shut down upon loss of primary air.

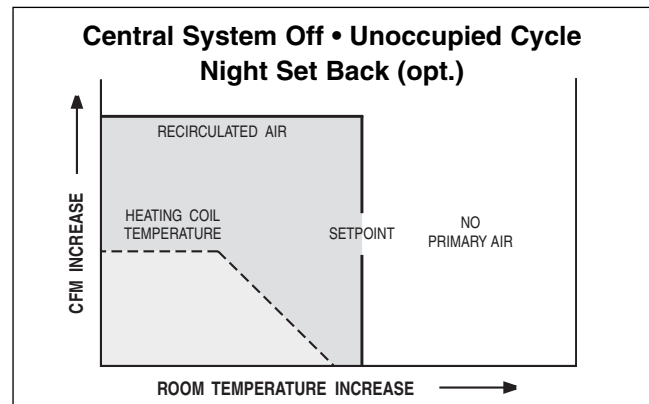
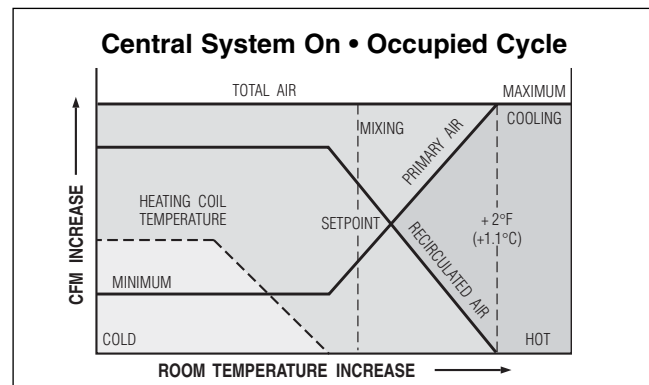

D

UNDERFLOOR FAN POWERED TERMINAL UNITS

Optional Terminal Unit Liners For 'IAQ' Sensitive Applications

Nailor offers several options for fan powered terminal unit applications where the maintenance of a high Indoor Air Quality is a primary concern. Specific 'IAQ' liners are designed to address applications where the issue of fiberglass insulation eroding and entering the airstream is a concern and/or to reduce the risk of microbial growth.

The sound power levels published in this catalog for fan powered terminal units are based upon testing with standard dual density fiberglass insulation. Dual density insulation is surface treated to prevent erosion and was developed to optimize attenuation for terminal unit applications. Cataloged discharge sound power levels for fan powered terminals are not significantly affected by the different liner options, however radiated sound levels may escalate depending on the terminal model and liner selection. Contact your Nailor representative for further information.

Fiber-Free Liner



Fiber-Free liner.

A new offering that totally eliminates fiberglass; Nailor's Fiber-Free liner is 3/4" (19) thick, closed cell elastomeric foam. The liner has excellent thermal insulating characteristics. The foam does not absorb water, reducing the likelihood of mold or bacterial growth.

The Fiber-Free liner surface is smooth, so that dirt and debris won't accumulate, durable, erosion resistant and washable.

Complies with the following standards and tests:

- NFPA 90A Supplementary materials for air distribution systems.
- ASTM E84 and UL 181 (25/50) Smoke and Flame spread.
- ASTM C1071, G21, G22. No bacterial or fungal growth.
- Acoustical attenuation of radiated sound is reduced compared with standard dual density fiberglass insulation.

Steri-Liner

Steri-Liner is an internal insulation designed to reduce the risk of microbial growth within the terminal. A smooth non-porous facing provides a vapor barrier to moisture and reduces the risk of microorganisms becoming trapped. It also facilitates cleaning and prevents insulating material erosion. Damage to the liner though, will expose fiberglass particles to the airstream.

- 13/16" (21) thick, 4 lb./sq. ft. (64 kg/m³) density rigid fiberglass with a fire resistant reinforced aluminum foil-scrim-kraft (FSK) facing on all panels in the mixing chamber.
- Meets the requirements of NFPA 90A and UL 181 for smoke and flame spread and the bacteriological requirements of ASTM C665. Will not support the growth of fungi or bacteria.
- No exposed edges. Steri-Liner features 'notch and tuck' fabrication and full seam length steel Z-strip construction providing both superior edge protection and an extremely rigid terminal.

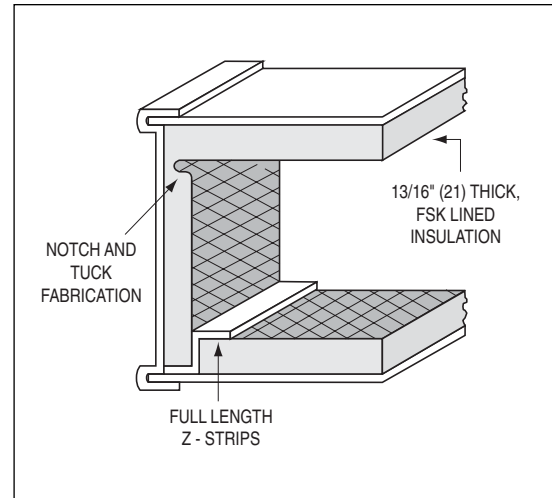

Steri-Liner detail on 38S Series fan powered terminal unit.

Solid Metal Liner

Nailor also offers a solid inner metal liner that completely isolates the standard insulation from the airstream within the terminal mixing chamber. Solid metal liners offer the ultimate protection against exposure of fiberglass particles to the airstream, all but eliminating the possibility of punctures exposing fiberglass. This option is also resistant to moisture. The encased insulation still provides thermal resistance and radiated sound attenuation, but acoustic absorption of discharge sound is eliminated.

Fabricated as a box within a box to separate all surfaces and exposed edges of the insulation.

Perforated Metal Liner

Provides additional security and retains standard dual density fiberglass insulation or optional Steri-Liner insulation reducing possibility of long term erosion or breakdown.

D

UNDERFLOOR FAN POWERED TERMINAL UNITS

Suggested Specifications • Underfloor Fan Powered Terminal Units • Model Series 38S

PART 1 – GENERAL

1.01 RELATED DOCUMENTS

A. The requirements of the general conditions, supplementary conditions, and the following specification sections apply to all work herein:

1. Section 15??? -- General.
2. Section 15??? -- Scope of Work.
3. Section 15??? -- Design Conditions.
4. Section 15??? -- Electric Motors and Controllers.
5. Section 15??? -- Access Doors and Color Coded Identification in General Construction.
6. Section 15??? -- Ductwork and Sheet Metal.
7. Section 15??? -- Testing, Balancing, and Adjusting.

1.02 SUMMARY

A. Furnish and install all air terminal units herein specified and as indicated on the drawings.

1.03 REFERENCE STANDARDS

A. All air terminal units shall be designed, manufactured, and tested in accordance with the latest applicable industry standards including the following:

1. ANSI/ASHRAE Standard 130-96.
2. ARI Standard 880-98.
3. Underwriters Laboratories UL Standard 1995.
4. Underwriters Laboratories UL Standard 1996.

1.04 QUALITY ASSURANCE

A. All equipment and material to be furnished and installed on this project shall be UL or ETL listed, in accordance with the requirements of the authority having jurisdiction, and suitable for its intended use on this project. Space limitations shall be reviewed to ensure that the equipment will fit into the space allowed.

B. All equipment and material to be furnished and installed on this project shall be run tested at the factory and results of that testing shall be tabulated and provided to the engineer when the equipment ships to the job site. See paragraph 2.03 J for specific requirements.

C. All equipment and material to be furnished and installed on this project shall have been pre-tested in a mock-up facility suitable to the engineer. The test shall be as described in 2.03 D. The test results shall be supplied with the equipment submittal.

1.05 SUBMITTALS

A. The following submittal data shall be furnished according to the conditions of the construction contract, Division 1 specifications, and Section 15010 and shall include but not be limited to:

1. **Underfloor Fan Powered Variable Air Volume Terminal Units**, complete with capacity data, test data, construction details, physical dimensions, electrical characteristics, etc.

1.06 ACOUSTICS

Section A of this acoustical specification describes sound power levels as tested to ARI 880 and ASHRAE 130. These are not the selection criteria for this specification. The selection criteria will be in section B where sound pressure readings are taken in an

actual mock-up that will exhibit worst case performance for the purpose of guaranteeing equipment performance when the building is commissioned and turned over to the occupant. Section A is important in that it provides a guideline for the minimum performance that the terminal units will have to meet in order to anticipate performance that will be acceptable under section B.

A. Sound Power Acoustical Performance:

1. **Discharge Noise:** Maximum permissible sound-power levels in octave bands of discharge sound through discharge ducts from terminal units operated at an inlet pressure of 0.1" w.g. and the maximum amount of air volume shown on the project mechanical drawings leaving the terminal unit and entering the reverberant chamber shall be as follows:

DISCHARGE SOUND POWER (dB re 10 ⁻¹² Watt)		
Octave Band	NC-35	NC-40
2	64	67
3	65	67
4	66	68
5	64	66
6	61	63
7	59	62

2. **Radiated Noise:** Maximum permissible radiated sound-power levels in octave bands of radiated transmission from terminal units operated at an inlet pressure of 0.1" w.g. and the maximum scheduled air quantity in an installed condition over occupied spaces shall be as follows:

RADIATED SOUND POWER (dB re 10 ⁻¹² Watt)		
Octave Band	NC-35	NC-40
2	64	68
3	56	61
4	49	54
5	48	53
6	47	52
7	51	56

B. Sound Pressure Acoustical Performance:

Each size of each terminal unit to be used on this project shall be completely laboratory tested for air performance and acoustics. Performance to NC 30, 35, 40 and 45 shall be charted for each size unit showing its maximum and minimum range limits under each NC condition listed above. If heater options change the overall performance, then the equipment shall be shown with electric and hot water coils in addition to no heat configurations. This data shall be submitted with the equipment submittal. Units that comply with the sound power data listed above may comply with the sound pressure performance. Testing is required to determine compliance and the performance range. Units that do not comply with the sound power performance in paragraph 1.06 A. probably will not comply with the sound pressure requirements or will have restricted ranges of acceptance.

1.07 WARRANTY

Manufacturer shall warrant equipment for one year from start up or 18 months from shipment.

D

UNDERFLOOR FAN POWERED TERMINAL UNITS

Suggested Specifications • Underfloor Fan Powered Terminal Units • Model Series 38S

PART 2 – PRODUCTS

2.01 UNAUTHORIZED MATERIALS

A. Materials and products required for the work of this section shall not contain asbestos, polychlorinated biphenyl's (PCB) or other hazardous materials identified by the engineer or owner.

2.02 ACCEPTABLE MANUFACTURERS

A. These specifications set forth the minimum requirements for underfloor fan powered VAV terminal units. If they comply with these specifications, underfloor fan powered VAV terminal units manufactured by one of the following manufacturers will be acceptable:

1. Nailor Industries.

2.03 VARIABLE PRIMARY AIR VOLUME FAN POWERED TERMINAL UNITS

A. Furnish and install underfloor fan powered VAV terminal units as indicated on the drawings. The units shall be designed and built as a single unit and provided with or without a primary variable air volume damper that controls the primary air quantity in response to a temperature control signal. The damper construction shall be rectangular with multiple opposed blades designed to operate on a 45° arc. Blades shall be heavy gauge galvanized steel, single thickness construction with heavy-duty gasket glued to the blades. Units shall be suitable for pressure independent control with [analog electronic or electronic DDC] controls. The units shall contain a fan and motor assembly and [electric or hot water] heating coils where scheduled and/or chilled water cooling coils where scheduled or indicated on the drawings. The fan shall provide a constant volume of discharge air at all air blending ratios from minimum to maximum scheduled primary air quantities and zero to 100% return airflow rates and shall be controlled in sequence as outlined hereinafter. The space limitations shall be reviewed carefully to ensure all terminal units will fit into the space provided including National Electric Code clearances required in front of all panels containing electrical devices. Units shall have removable access doors or panels of minimum 20 gauge galvanized steel on the top of the terminal unit that shall provide access to service the fan, electric motor and all internal components. Panels shall be attached with [screws or quick connect latches or hinges]. Unit shall be fully lined with at least 1/2" thick, dual density fiberglass insulation complying with NFPA 90 for fire and smoke resistivity and UL 181 for erosion. Any cut edges of insulation shall be coated with NFPA 90 approved sealant. Drain pans shall be of stainless steel construction and internally pitched to provide positive drain free performance. Casing leakage shall not exceed 2% of terminal rated airflow at 0.1" wg. interior casing pressure. Provide a filter rack with a 1" thick throwaway filter to be used during construction.

When scheduled, the terminal unit manufacturer shall provide flow curves for the primary air sensor clearly labeled and permanently attached on the bottom or side of each fan terminal.

The unit shall include all equipment and controls as required to provide a complete and operating system with at least the following equipment and controls:

1. Single point electrical connection for the voltage/phase as scheduled in the contract documents. See electrical drawings for power feeder arrangements. Motors shall be rated at [277 single phase or 120 single phase] as scheduled in the contract documents.
2. A toggle disconnect switch for cooling only units, or a door interlocking disconnect switch for terminal units with electric heating coils. All disconnecting devices shall be sized and located as required to disconnect all ungrounded power conductors to all

internal electrical components.

3. Individual overcurrent protection devices as required to protect individual units and transformers.

4. If there is a pressurized primary air source, the primary inlet shall be equipped with an inlet collar sized to fit the primary duct size shown on the drawings. Any transitions shall be provided and installed by the Division 15 mechanical subcontractor. The inlet collar shall provide at least a 6" length with a 1/8" high raised single or double bead located approximately 1 1/2" from the inlet connection. The primary and fan design cfm settings shall be clearly and permanently marked on the bottom of the unit along with the terminal unit identification numbers. Each terminal unit with a primary air inlet and damper shall incorporate a Nailor Diamond Flow sensor with four pick up points on each side to insure that with typical duct turbulence, the controller fidelity shall be +/- 5% of set volume even with a hard 90° elbow at the inlet. Static variation of 0.5" wg. to 6.0" wg. shall not affect the flow reading. Provide a transformer with 24 volt AC secondary to provide power for the unit's controls and the Division 17 controls. The VAV terminal unit manufacturer and the Division 17 building controls subcontractor shall verify compatibility of the multi-point flow sensors with transducer and DDC microprocessor furnished under Division 17 prior to bidding this project.

5. The outlets shall be rectangular or round as required. Unit shall be designed to fit between the floor pedestals with no bridging required.

6. Fan motor assembly shall be a forward curved centrifugal fan with a direct drive motor. Motors shall be AO Smith or General Electric ECM and/or Nailor EPIC variable-speed DC brushless motors specifically designed for use with a single phase, 120, 208, 240, 277 volt, 50 or 60 Hertz electrical input. Motor shall be complete with and operated by a single phase integrated controller/inverter that operates the wound stator and senses rotor position to electrically commutate the stator. All motors shall be designed for synchronous rotation. Motor rotor shall be permanent magnet type with near zero rotor losses. Motor shall have built-in soft start and slewed speed change ramps. Motor shall be able to be mounted with shaft in horizontal or vertical orientation. Motor shall be permanently lubricated with ball bearings. Motor shall be direct coupled to the blower. Motor shall maintain a minimum of 65% efficiency over its entire operating range. Provide isolation between fan motor assembly and unit casing in at least 4 locations to eliminate any vibration from the fan to the terminal unit casing. Provide isolation between the motor and blower as well as between the blower and casing. Provide anti-back rotation system or provide a motor that is designed to overcome reverse rotation and not affect life expectancy.

a. The manufacturer of the fan powered terminal units shall set the fan discharge cfm at the factory. If the fan powered terminal unit manufacturer cannot factory set the fan cfm, he shall send factory technicians to the field to adjust the GE ECM and/or Nailor EPIC motor and the associated controller/inverter to the discharge CFM indicated in the schedules in the contract documents. Fan cfm shall be constant within ± 5% regardless of changes in static upstream or downstream of the terminal unit after it is installed in the field. Fan cfm is to be set with a potentiometer and digital meter. Neither SCR's nor rheostats shall be an acceptable means of setting the fan cfm. The terminal unit manufacturer shall provide one speed adjustment device to the owner for field adjustment of the fan speed should construction or design changes become necessary.

Suggested Specifications • Underfloor Fan Powered Terminal Units • Model Series 38S

PART 2 – PRODUCTS

b. A witnessed test shall be conducted by the fan powered terminal unit manufacturer in an independent testing laboratory to confirm that the terminal unit and the fan motor as an assembly performs in accordance with this specification. If the fan powered terminal unit and DC motor as an assembly fails to perform as specified and as scheduled on the drawings, the terminal unit manufacturer shall make adjustments and take all corrective action as necessary at the terminal unit manufacturer's sole expense.

7. The terminal unit shall be listed in accordance with UL 1995 as a composite assembly consisting of the terminal unit with or without the electric or hot water heating device and or chilled water cooling device.

8. Heating Options:

9. **If there is a pressurized primary air duct**, the terminal unit shall be capable of operation as described herein with inlet static pressure of .05 at full cooling with no mixing of induced and primary air. [The sequence of operation should be described here if not part of the temperature controls specifications.] The primary air damper shall be of a design that shall vary primary air supply in response to [a pneumatic or an electronic] signal. Primary air damper close-off leakage shall not exceed 2% of the maximum ARI rated primary air cfm as shown in the manufacturer's catalog for each size terminal unit at 3" w.g. inlet static pressure. Submit damper leakage test data to the engineer for review. Damper linkage and actuator shall be located inside the terminal unit. Damper connection to the operating shaft shall be a positive mechanical through bolt connection to prevent any slippage. Provide non-lubricated Delrin or bronze oilite bearings for the damper shaft. The primary air damper in conjunction with the [pneumatic or analog electronic controller or DDC microprocessor] furnished under Division 17 shall be selected to provide accurate control at low primary air velocities. The total deviation in primary airflow shall not exceed \pm 5% of the primary air cfm corresponding to a 300 fpm air velocity through the primary air damper.

10. **If the unit incorporates a mixing chamber**, the mixing chamber shall provide mixing of primary air and plenum air from 100% primary air to 0% primary air. Mixing of the primary and secondary air streams shall be as described in paragraph 2.03 D. The deviation of fan supply air at design conditions and primary airflow rates from 100% primary air to 0% primary air shall not exceed 5%.

11. Provide duct inlet and outlet connections as indicated on the drawings.

12. All components, including all controls and wiring, shall be factory installed, except the room sensor or thermostat. No field assembly will be allowed. The unit shall be complete and suitable to accept the following field connections if required:

- a. Primary duct.
- b. Secondary duct.
- c. Single point electrical connection. See drawings for control box locations required for each terminal unit.
- d. DDC controller control signals and wiring.
- e. Room sensor connection.

B. The terminal unit shall be capable of operating throughout the full cataloged primary airflow range with an inlet static pressure of 0.10" w.g. or less. All downstream static pressure requirements are to be supplied by the terminal unit internal fan. See the schedules on the contract documents for static pressure requirements.

C. The control sequence shall be as specified in Division 17.

D. Each size of each terminal unit to be used on this project shall be completely laboratory tested for air performance and acoustics. The acceptability of the independent testing laboratory is subject to review by the owner, project acoustical consultant, and the engineer. The terminal unit manufacturer shall submit complete details, brochures, instrumentation information, etc., for review. The laboratory shall be capable of properly testing the largest terminal unit on this project. See paragraph 1.06 B for acoustic guidelines.

E. After the manufacturer has submitted certified copies of the laboratory air performance and acoustical performance test results to the engineer, the engineer may witness the laboratory tests to verify compliance with the Specifications. See Section 15???? for additional submittal and certification requirements.

I. All fan powered terminal units shall be identified on the top of the unit (minimum 1/2" high letters) and on the shipping carton, with the floor and box number that identifies it along with the CFM settings. Every unit shall have a unique number combination that matches numbers on the contractor's coordination drawings as to its location and capacity and is coordinated with the DDC controller and the Division 17 Building Control System submittal drawings.

J. The manufacturer will verify the operation of each unit before shipment. Testing shall include at least the following:

1. Apply electric power to the unit.
2. Start the fan and verify fan rotates properly.
3. The manufacturer shall factory or field adjust the GE ECM and/or Nailor EPIC motor and associated controller/inverter to the discharge CFM indicated in the schedules. (Refer to paragraph 2.03 A.2.e.1 hereinbefore.)
4. Energize the electric heat through the electric heating coil relay. Verify the signal with a voltmeter and ammeter to ensure proper heater operation.
5. De-energize the electric heating coil and verify the signal with a voltmeter to ensure the heater is de-energized.
6. If DDC controls are mounted, disconnect the primary air damper actuator from the DDC terminal unit controller. Provide separate power source to the actuator to verify operation and rotation of damper. Drive the damper closed and verify by feel or observation that damper is driven fully closed. Return primary air damper to the fully open position prior to shipment.
7. Provide a written inspection report for each terminal unit signed and dated by the factory test technician verifying all terminal unit wiring and testing has been performed per the manufacturer's testing and quality assurance requirements.

D UNDERFLOOR FAN POWERED TERMINAL UNITS

D

UNDERFLOOR FAN POWERED TERMINAL UNITS